

Transistor Switch Training PCB Component List and Instructions – Version 2

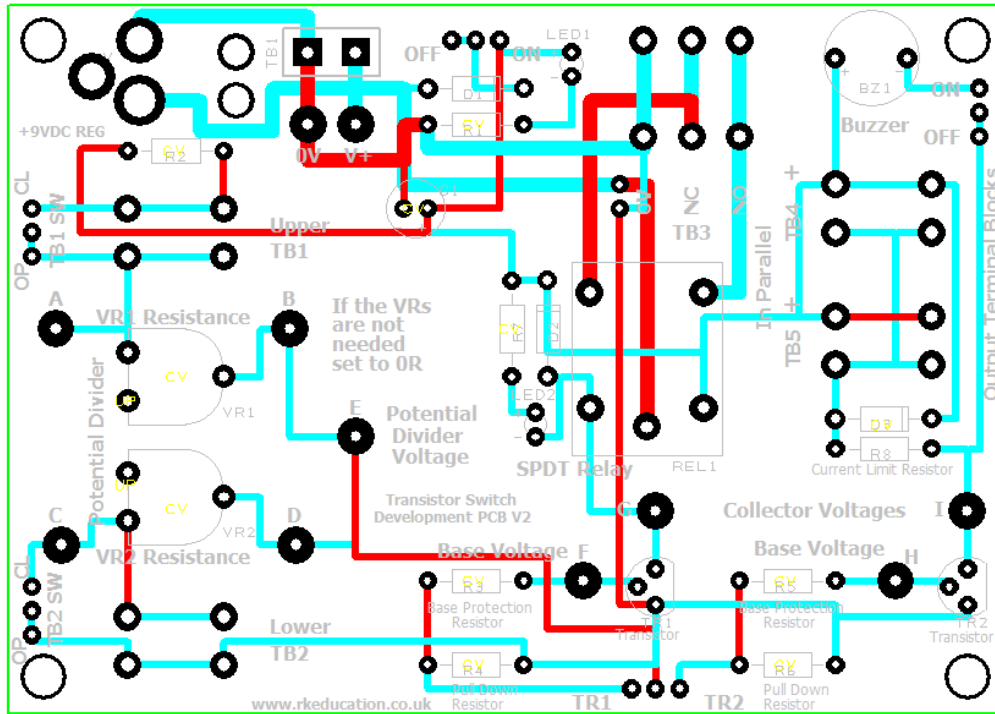

PCB layout

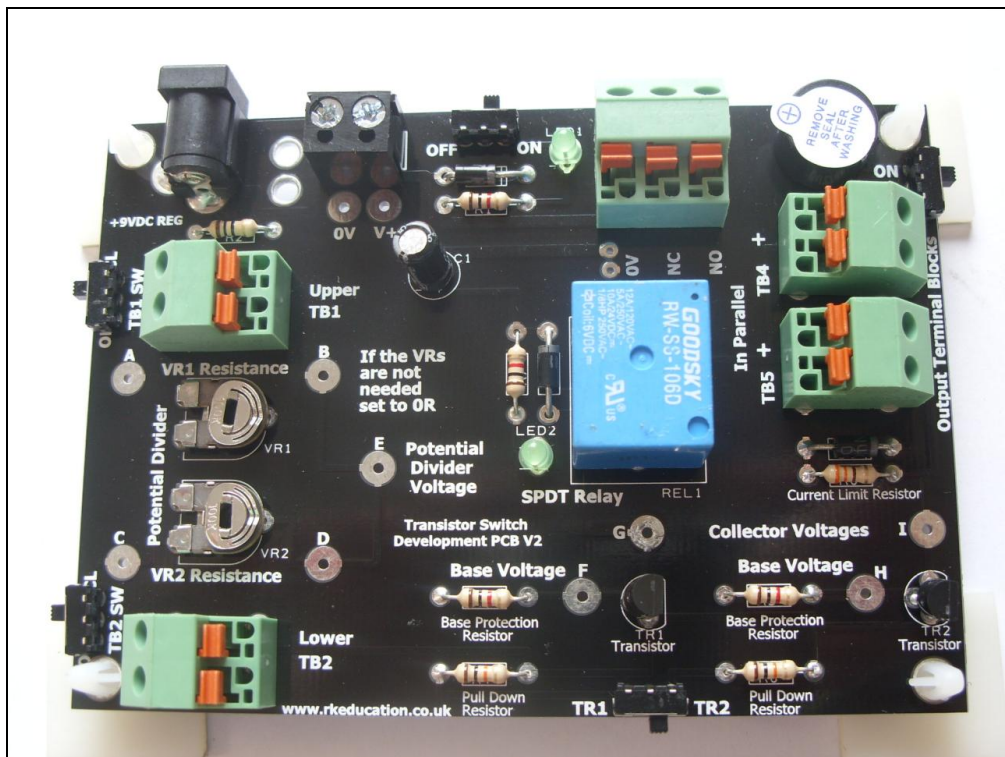

Constructed PCB

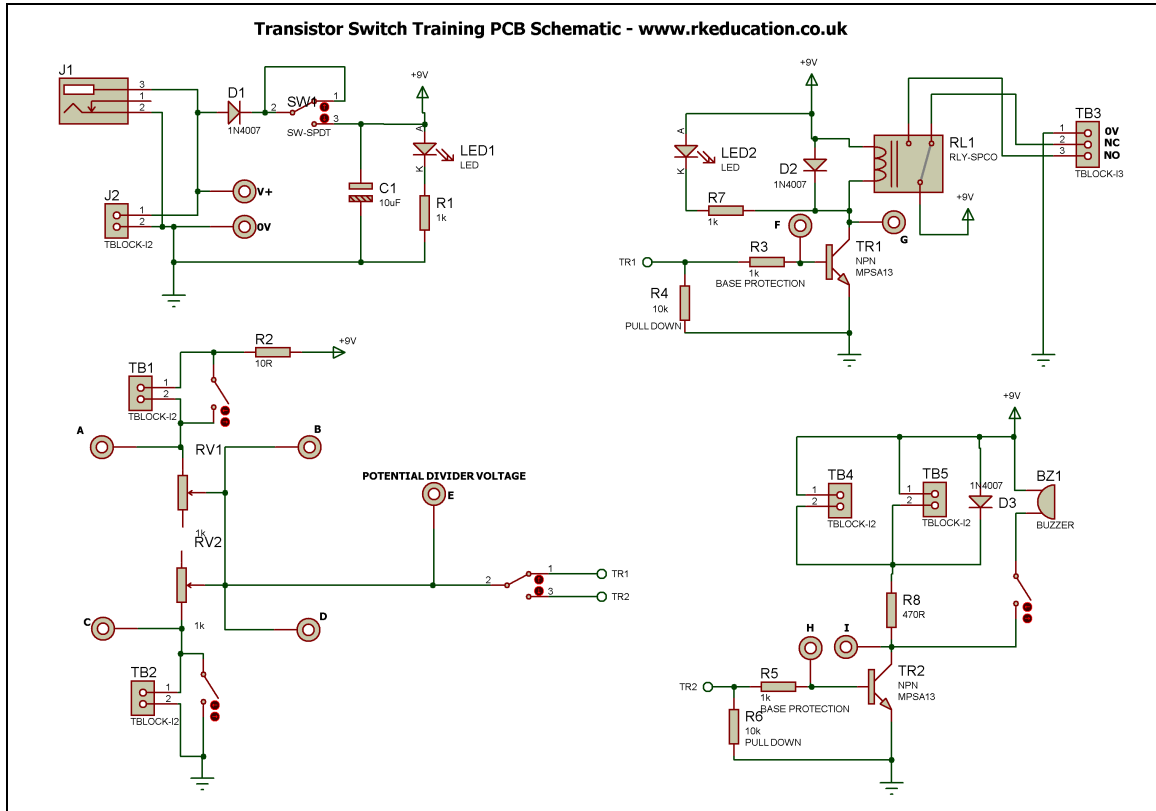

Schematic Diagram

Description

This system has been specifically designed to be used alongside the Transistor Switch Project. Using this system allows students to gain an understanding of the operation and application of the transistor switch circuit and this system also helps students make important decisions that will affect the final outcome of their project.

- Simple, low cost, portable and curriculum-based
- Can be battery powered or powered by a DC adapter
- Uses a potential divider and transistor to switch on an output
- Allows students to model a light, temperature and moisture sensing circuit
- Allows students to test their designs prior to final construction
- Screwless terminal blocks are used to allow students to easily insert different values for the potential divider section
- Clear silkscreen text has been used to aid learning
- Includes test points that are used with a digital multi meter – DMM – to measure values
- Professional double-sided PCB with clear white silkscreen and solder-resist
- Suitable for **Key Stages 2, 3 & 4** (ages 7 to 16)
- High quality, professional double sided PCB
- Multiple outputs – transistor driven, buzzer and SPCO relay
- Designed to be used with the **Transistor Switch Project**
- Perfect for nightlights, temperature alarms and moisture detectors

Component List

BZ1 – PCB mount buzzer
C1 – Smoothing cap, 10uF electrolytic or suitable alternative
DC power socket – 2.1mm
D1 – D3 ~ 1N400x
R1, R3, R5, R7 – 1k ~ BROWN, BLACK, RED
R2 – 10R ~ BROWN, BLACK, BLACK (this can be changed to 0R)
R4, R6 – 10k ~ BROWN, BLACK, ORANGE
R8 – 470R ~ YELLOW, VIOLET, BROWN
REL1 – SPCO relay 6VDC coil
LED1, LED2 – 3 or 5mm LED (green) for power indicator
TR1, TR2 – MPSA13 darlington transistor or equivalent
VR1, VR2 – 100k preset resistor 085 type or equivalent
2 way screwless terminal blocks x4
3 way screwless terminal block x1
PCB feet x4
Ultra miniature slide switch x5
TB1 – 2 way 5mm terminal block

When constructing always start with the components that have the lowest profile and work high, for example start with the resistors. For this kit please solder the screwless terminal blocks last. If a battery clip is being the leads should be threaded thorough the 2 holes to the left of TB1, it is advisable to twist the wires of the battery clip together.

Please only attempt to construct this unit if you are confident you are able to do this, if you are not confident please purchase a constructed unit. We will not accept responsibility for damaged and faulty units due to poor soldering.

Instructions

This PCB has been designed to be used alongside the Transistor Switch Project. For details of the **Transistor Switch Project** and other projects please visit our website, www.rkeducation.co.uk

There are 6 areas to familiarize yourself with.

1. Power
2. Pads for measuring values
3. Screwless terminal blocks
4. Potential divider
5. Transistors
6. Outputs

Connecting Power

The first step is to power the PCB, use either a 9VDC power supply with a 2.1mm plug, it is also possible to use a bench DC power supply or 9V PP3 battery attached a battery clip and screwed into TB1, which ever method is used always check the polarity of the power supply. This unit is designed to work at 9VDC.

Never use mains electricity with this unit, only use low voltage power supplies or batteries.

The system can now be turned on using the ultra-miniature slide switch at the top of the PCB, it is marked **ON** and **OFF**. The green power LED should light up, it is to the right of the power switch. If it does not light up it may indicate faulty batteries or power supply, check them carefully or a short circuit.

Pads for measuring values

There are several large pads around the PCB that are used to measure voltages and resistances so the user can observe what is happening. There pads located either side of the variable resistors – **VR1** and **VR2** – are used to measure the resistance of the variable resistors, these are labelled **A,B, C** and **D**. To measure the resistance simply put the probes from a digital multi meter, DMM, on each of the pads. There is a further pad labelled **E** and this is used to measure the voltage output from the potential divider, to measure the voltage place probes between **0V** and **E**. There are 2 further pads that are located near the transistors TR1 and TR2, these are to measure the base and collector voltages, to measure these voltages use a DMM between the 0V pad and either the base or collector pad. The pads are labelled **F, G, H** and **I**, to measure a voltage place DMM probes between 0V and the appropriate pad.

Screwless terminal blocks

This PCB has been designed around screwless terminal blocks, these allow components to be quickly and easily inserted and changed. Screwless terminal blocks are located around the PCB where the user may want to change/vary components, for example changing an output. This innovative approach allows for flexible project outcomes as the student experiment with their designs prior to manufacture in order to achieve the desired practical outcome. To insert a component simply press the levers on the terminal block and insert the leads into the holes, care should be taken to ensure a good contact.

Potential/Voltage Divider

This transistor switch circuit is based around the potential divider, the voltage from the potential divider will turn on or off the transistor which in turn will turn on or off an output. A potential divider divides a voltage, the output voltage from the divider is dependent on values of resistance. When two resistors of equal value (e.g. 10K) are connected across a supply, current will flow through them. If a meter is placed across the supply it will register 9V. If the meter is then placed between the 0V and the middle of the two resistors it will read 4.5v. The battery voltage has been divided in half. This is useful when using resistive sensors such as LDRs and thermistors, when either is used with a fixed resistor in series a simple sensor circuit is created, if an LDR is used then we have a light sensor and when a thermistor is used we have a temperature sensor. The voltage from the potential divider is this circuit can be measured using a DMM by placing DMM probes between **0V** and **E**. The resistances of the 2 variable resistors can be measured using a DMM and placing the probes on the appropriate test point pads.

Transistors

The potential divider in this circuit is used to switch on or off **TR1** or **TR2** which are MPSA13 darlington transistors. The MPSA13 will switch on when approximately 0.7VDC is applied to the base (middle leg). This type of circuit is known as a transistor switch circuit. There is a base protection resistor (1k) that protects the base from excessive currents. The collector of the transistor is connected to the outputs. The collector and base voltages can be measured with a DVM in order to observe the transistor operating. When using the PCB the transistor that needs to be used should be selected with the ultra miniature slide switch marked **TR1 TR2**. One transistor is used to control the relay **REL1** and the other controls the **Output Terminal Blocks** and PCB mounted **Buzzer**.

Outputs

The outputs are divided into 2 sections with each of the transistors controlling one of the sections. **TR1** controls the relay output **REL1** and **TR2** controls the **Output Terminal Blocks** and PCB mounted **Buzzer**.

The collector of the transistor TR1 is connected to REL1 and when TR1 is selected applying a high enough voltage from the potential divider to the base will turn on TR1 and thus energise the relay. The relay contacts take their power from the main supply so therefore the relay switches 9VDC. By connecting a transducer to the 3 way terminal block the transducer can be turned on and off depending on the state of the potential divider. As an example a motor can be connected to the 3 way terminal block which gives access to the relay contacts. There are 3 connections, **OV**, **NC** – normally connected and **NO** – normally open. It is assumed the motor will have flying leads soldered to the terminals and it is advisable to also solder a suppression capacitor to the motor terminals. Attach one flying lead into **OV** and the other to **NO**, when the relay is energised and the click is heard the contacts change over and the motor will turn on, when the relay turns off the motor will turn off. By swapping **NO** and **NC** this is reversed and the motor will be turned on when the relay is not energised and the motor will turn off when the relay is energised. The motor can be changed for other transducers such as light bulbs and buzzers.

The collector of transistor 2 is connected to 3 outputs, 2 of these are in parallel and are protected with a resistor (470R) and are intended for use with LEDs. The top output is connected to a buzzer and this buzzer can be turned off with an ultra miniature slide switch near to the buzzer marked **ON OFF**. When **TR2** is selected it will turn on when a high enough voltage is applied to the base of the transistor and the outputs will turn on until the base voltage drops below the point at which the transistor turns on. To add an LED simply insert it into one of the terminal blocks marked **Output Terminal Blocks** observing the fact that LEDs have polarity, the longer leg should be inserted above the shorter leg.

A good way to observe the potential divider turning the transistors on and off is to turn the ultra miniature slide switches **TB1 SW** and **TB2 SW** both to closed and vary **VR1** and **VR2**, this will turn the outputs on and off, in the case of the relay a distinct clicking will be heard. Use a DMM to observe the voltages at which things change state.

Using the PCB

Above and below the variable resistors VR1 and VR2 are 2 way screwless terminal blocks labelled **Upper** and **Lower** these are to allow components such as LDRs and thermistors to be inserted to make sensor circuits. Next to these terminal blocks are ultra miniature slide switches, these switches allow the terminal blocks to be shorted so they have no effect on the circuit, this is useful when observing how a potential divider works. To short the terminal block set the switch to **CL**. With the switches set to **OP** components such as LDRs, thermistors, moisture sensors and resistors can be added.

The PCB has been designed to be simple to use. In order to become familiar with the unit it is advisable to do the following.

- Set the switch at the bottom of the PCB to TR1
- Set the switches near the **Upper** and **Lower** terminal block of the potential divider to **CL**. This is because only the variable resistors are to be used
- Adjust the variable resistors using a terminal screwdriver, doing so should turn the relay on and off, a clicking will be heard, this is due to the voltage from the potential divider at the base of the transistor going above and below approx. 0.7VDC
- Try inserting a transducer in the 3 way screwless terminal block at the top of the PCB and turn it on and off by adjusting the voltage output from the potential divider
- Set the switch at the bottom of the PCB to TR2
- Insert an LED into an output terminal block, be sure to insert the longer leg above the shorter leg
- Adjust the variable resistors using a terminal screwdriver, doing so should turn the LED on and off, this is due to the voltage from the potential divider at the base of the transistor going above and below approx. 0.7VDC
- In order to observe the voltages use a DMM between **0V** and the appropriate test pad
- Observe the resistances on the variable resistors using a DMM with appropriate test pads

Now try the following

- Set the lower slide switch to **TR2**
- Take an LDR (light dependent resistor) and 0R resistor (one black band)
- Insert the LDR in the **Lower** terminal block and set **VR2** to 0Ω using a DMM
- Insert the 0R resistor in the **Upper** terminal block, set **VR1** to approx $50k\Omega$ using a DMM
- Insert an LED into an output terminal block – not the terminal block without a resistor
- Cover and uncover the LDR, this should turn the LED on and off
- If this does not happen adjust **VR1**, this adjusts the sensitivity
- Now swop the 0R and LDR, observe how the circuit behaves differently
- When VRx is set at the correct resistance measure using a DVM, make a note of the value. Then set VRx to 0Ω and insert a resistor of the measured value or nearest value into the appropriate terminal block
- The circuits are light and dark activated transistor switch circuits
- Use the buzzer in to make an alarm

This circuit can also be used with a thermistor to make a temperature activated transistor switch circuit and with a moisture sensor to make a moisture sensitive switch. If this is to be done repeat the steps above changing the appropriate components.

Use this PCB to help make design decisions when completing a project

Please visit our website

www.rkeducation.co.uk

If you have any comments or queries please email us at

technical@rkeducation.co.uk

