

RKPT40 Component List and Instructions

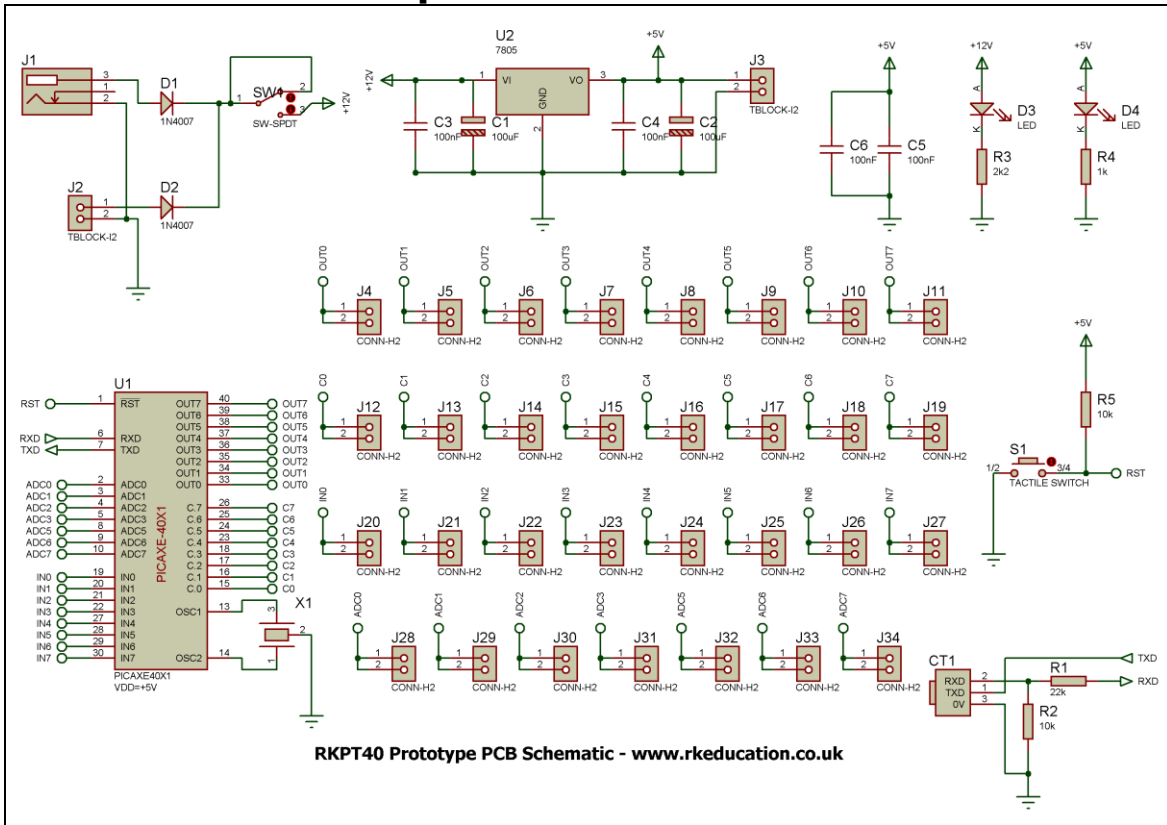

Schematic

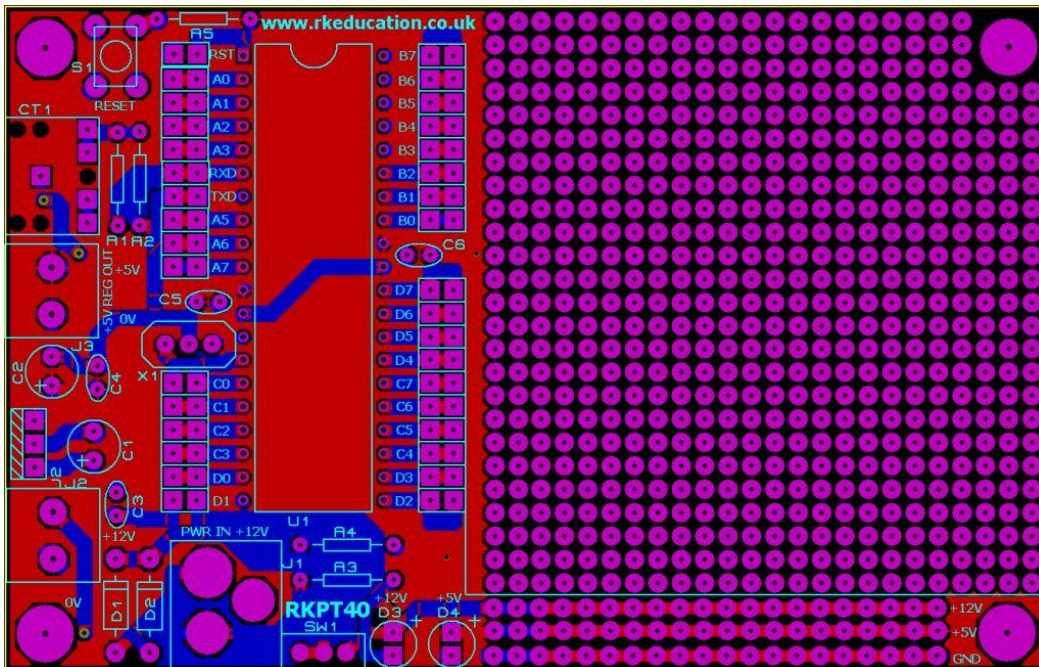

PCB layout

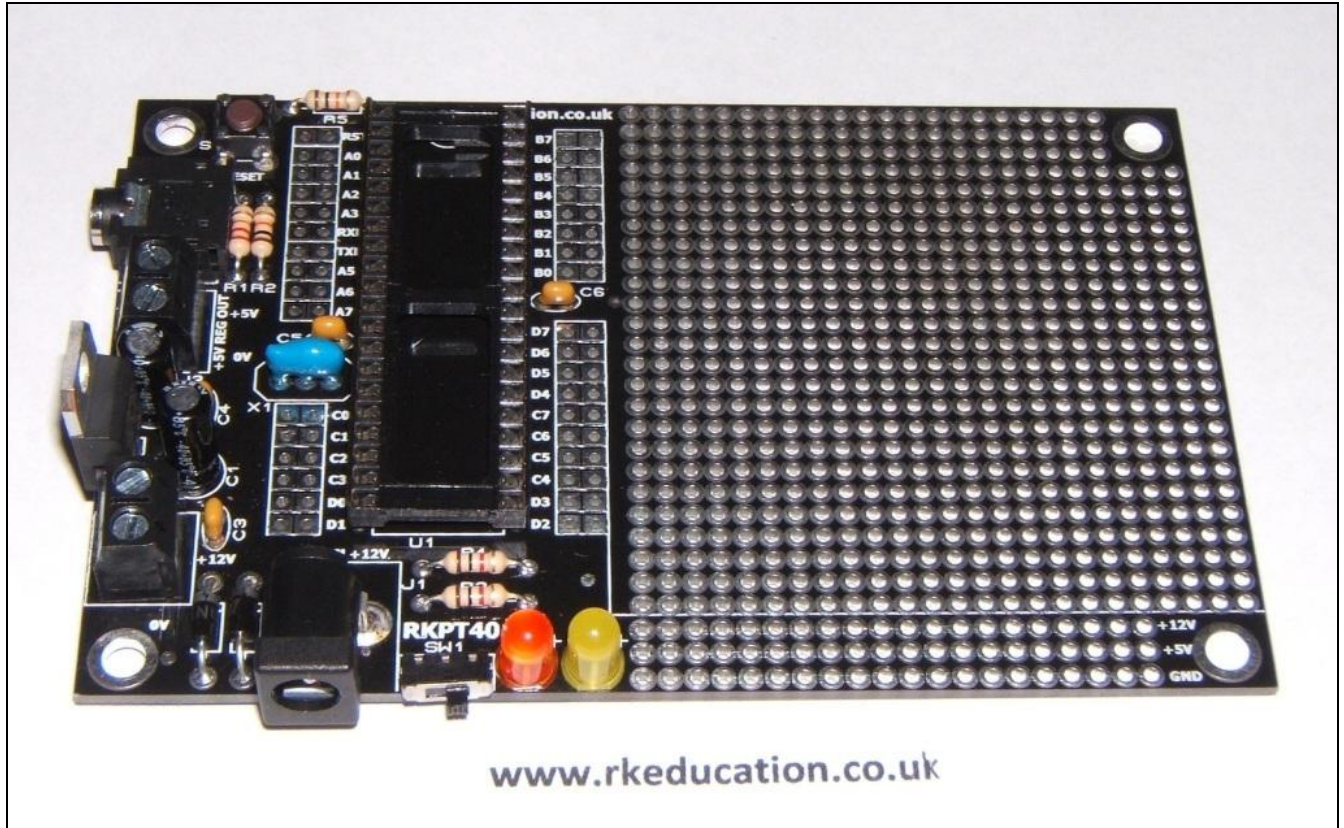

Constructed PCB

Description

The RKPT40 prototype project PCB has been designed to use 40 pin PIC microcontrollers such as PICAXE

- Software is downloaded from a PC into the microcontroller via a 3.5mm stereo socket
- The clock reference is from a ceramic resonator, 4MHz supplied
- All input and output pins have a PTH
- A large prototyping area
- Power rails on the prototyping area
- Power a terminal block or DC power socket
- +12VDC input and +5VDC regulated output
- 2 LEDs used to indicate power – +12V and +5V
- Power switch and LED power indicator

Component List

J1 – 2.1mm DC socket
J2, J3 – 2 way 5mm pitch terminal block
C1, C2 – 100uF electrolytic capacitor 25VDC
C3 ~ C6 – 100nF multilayer ceramic capacitor
D1, D2 – 1N4007
D3, D4 – 5mm LEDs yellow and orange (power indicators)
R1 – 22k ¼ watt resistor (red red orange)
R2, R5 – 10k ¼ watt resistor (brown black orange)
R3 – 1k8 ¼ watt resistor (brown grey red)
R4 – 1k ¼ watt resistor (brown black red)
CT1 – PCB mount 3.5mm stereo connector
S1 – 6mm tactile switch
SW1 - Ultra miniature slide switch for power switch
U1 – 40 way DIP socket with microcontroller e.g. PICAXE
U2 – 7805 voltage regulator TO220 package
X1 – 4MHz ceramic resonator

When constructing always start with the components that have the lowest profile and work high, for example start with the resistors and end on the 7805 voltage regulator.

Instructions

The PCB has been designed to use microcontrollers based on the PIC e.g. PICAXE, for instructions on how to use your chosen PIC please see the appropriate website.

Connecting Power

The power is connected to the terminal block marked PWR IN, the 0V input, usually black is put in the lower terminal and the +VE, usually red, is put in the upper terminal, power can also be supplied via the 2.1mm DC socket, a regulated 12VDC 1Amp power supply should be used. The circuit incorporates a 7805 voltage regulator and 5VDC is available at the terminal block +5V REG OUT, a heat sink may need to be added to the 7805 if a high current is required.

A power switch has been included and is labelled SW1.

Downloading software

Once the software has been written using the PICAXE Programming Editor (or equivalent) it can be downloaded into the PICAXE (or equivalent). This is downloaded using a download cable that connects either to your PC's serial port or USB port. Insert the download plug into the download socket and activate the program function in your Programming Editor. If all goes well it will tell you the program download was successful.

Using the prototype area

Using the prototype area is simple and how it is used is dependent on what is being done. Access to all of the pins of U1 is gained by through holes near the pins of U1, simply connect using jumper wires. The bottom 2 rows of the prototyping area are connected to 0V and +5VDC and are clearly marked on the PCB.

Please visit our website

www.rkeducation.co.uk

If you have any comments or queries please email us at

technical@rkeducation.co.uk

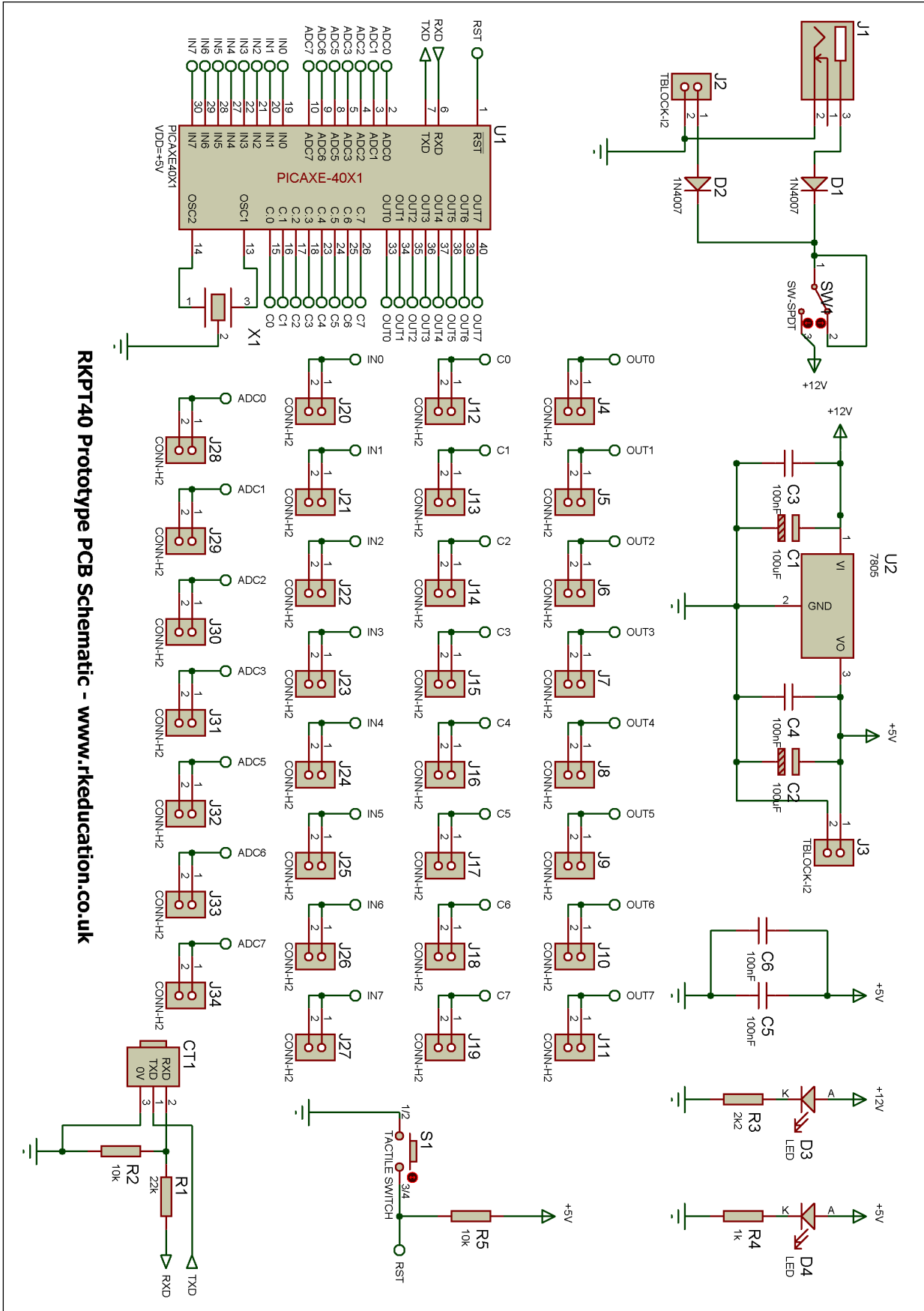

RKPT40 Prototype PCB Schematic - www.rkeducation.co.uk