

RKP18lp Component List and Instructions

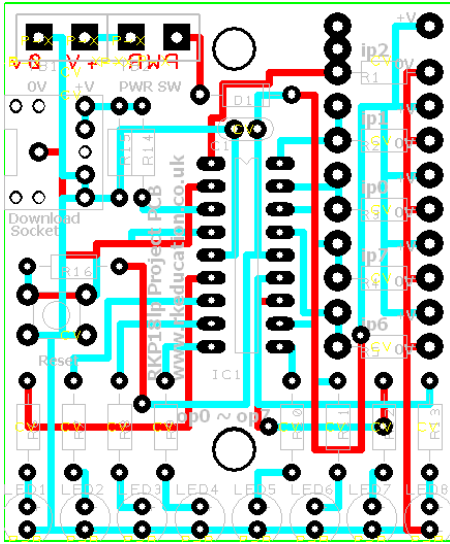

PCB layout

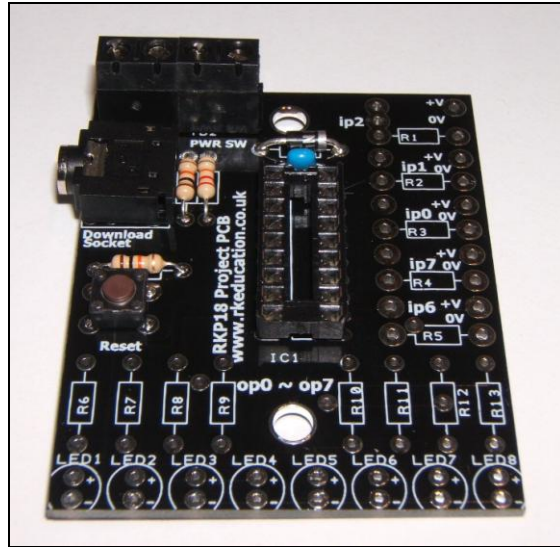

Constructed PCB

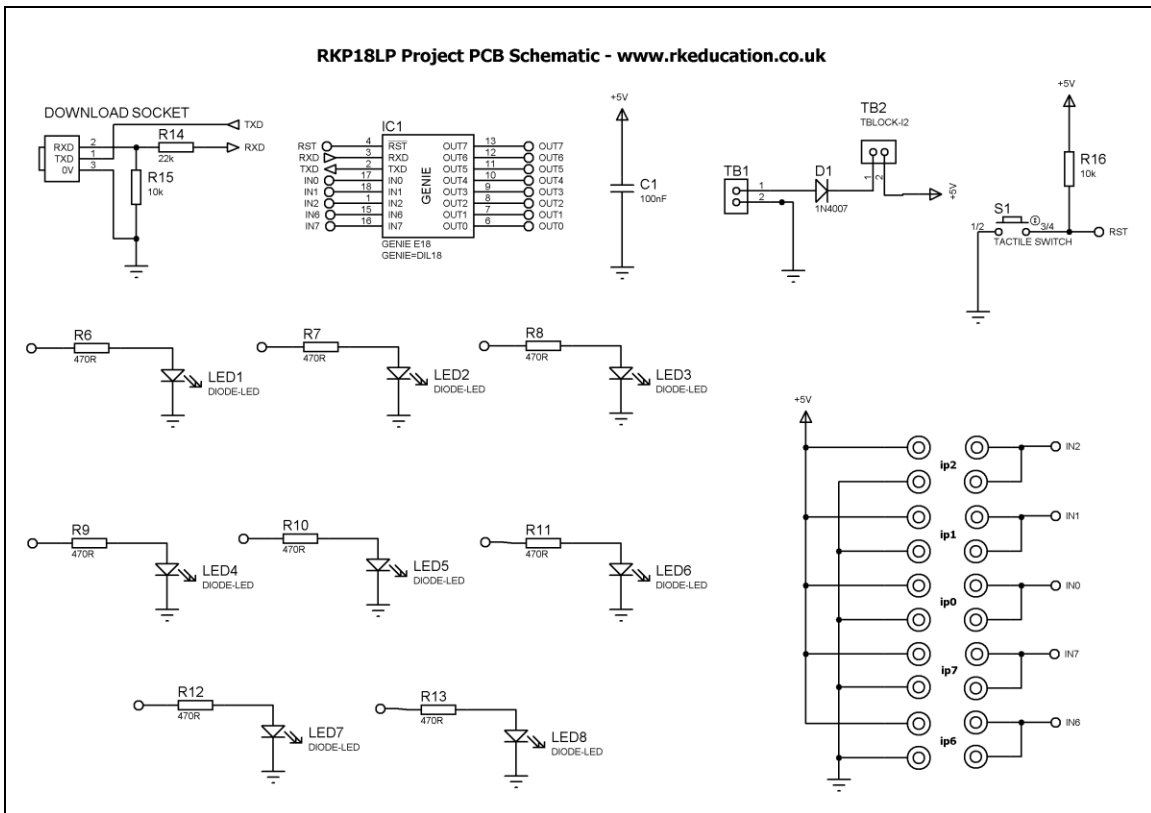

Schematic

Description

The RKP18lp project PCB has been designed to use PIC microcontrollers such as the Genie or PICAXE

- Software is downloaded from a PC into the microcontroller via a 3.5mm stereo socket – no need for a programmer
- The clock reference is from a the microcontrollers internal resonator
- 8 low power outputs are connected to resistors and are ideal for LEDs
- 5 potential divider inputs, 3 can be used as analogue
- 1 input can have a PCB mount potentiometer directly mounted

Component List

TB1 ~ TB2 - 2 way 5mm pitch terminal blocks

C1 – 100nF multilayer ceramic capacitor

D1 – 1N4007

IC1 – 18 way DIP socket with microcontroller e.g. Genie

R14 – 22k red red orange

R15 & R16 – 10k brown black orange

RESET – PCB mounting tactile switch

Software download socket – PCB mount 3.5mm stereo connector

Instructions

For instructions on using your chosen microcontroller, e.g. Genie, please see the appropriate website.

Connecting Power

The power is connecting the terminal block marked TB1, the 0V input, usually black is put in the left hand terminal and the +V, usually red, is put in the right hand terminal, a regulated 6VDC power supply should be used.

A power switch can be used and should be inserted into the terminal block marked PWR SW, if a power switch is not required short the terminals together

Downloading software

Once the software has been written using the Genie Programming Editor (or equivalent) it can be downloaded into the Genie (or equivalent). This is downloaded using a download cable that connects either to your PC's serial port or USB port. Insert the download plug into the download socket and activate the program function in your Programming Editor. If all goes well it will tell you the program download was successful.

Using the low power outputs

This PCB has been designed with LED projects in mind. To turn an output on simply turn on the corresponding output on in your software. The outputs are along the bottom of the PCB and from left to right are op0 ~ op7. A suitable value for the resistor may be 470R, LEDs will likely be attached using flying leads.

Inputs Ip0 ~ Ip7

These are used as digital inputs and Ip0, Ip1 and Ip2 can also be used as analogue inputs. They are arranged as potential dividers with the +V and 0V parts clearly marked, the centre of the potential divider or output are the 2 pads to the left hand side of the potential divider. Ip2 has been designed to allow a PCB mounting potentiometer to be soldered directly to the PCB.

They are connected to the microcontroller as follows,

- ip0 – pin17
- ip1 – pin18
- ip2 – pin1
- ip6 – pin15
- ip7 – pin16

Please see below for examples of using I/O

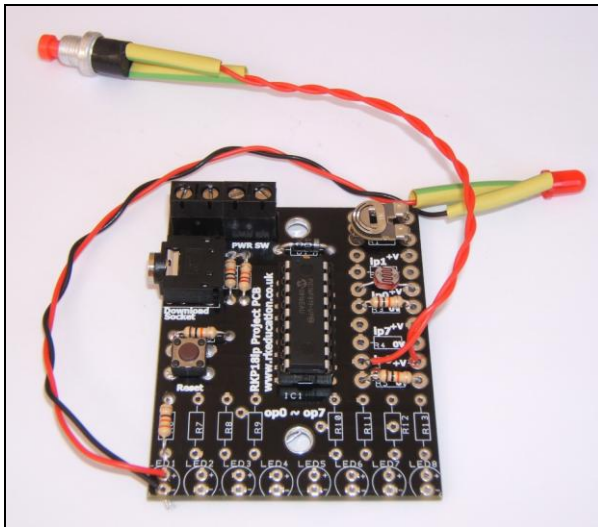

The microcontroller shown in the picture is a Genie.

Here is an example of using op0 with a red LED, ip2 with a 1k preset resistor, ip0 with an LDR and ip6 with a PTM switch.

The inputs are set up as potential dividers and can be used as digital or analogue inputs, if switches are being used then a 10k pull down or pull up resistor should be used.

Analogue values can be read by the Genie using the appropriate software function. As an example temperatures could be read using a thermistor and resistor potential divider.

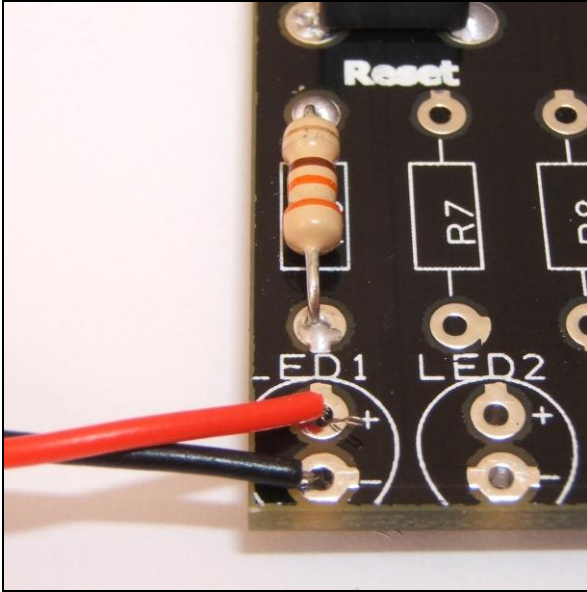

Here is the LED close up, to turn on this LED a high signal or logic 1 would be sent to op0, if op3 were being used then the signal would be sent to op3. There are 8 outputs and all can be used if needed and manipulated as required using software.

When inserting LEDs be careful with polarity, remember the long leg.

In this example a 330R resistor has been used but other values can be used. It is recommended not to use less than 270R.

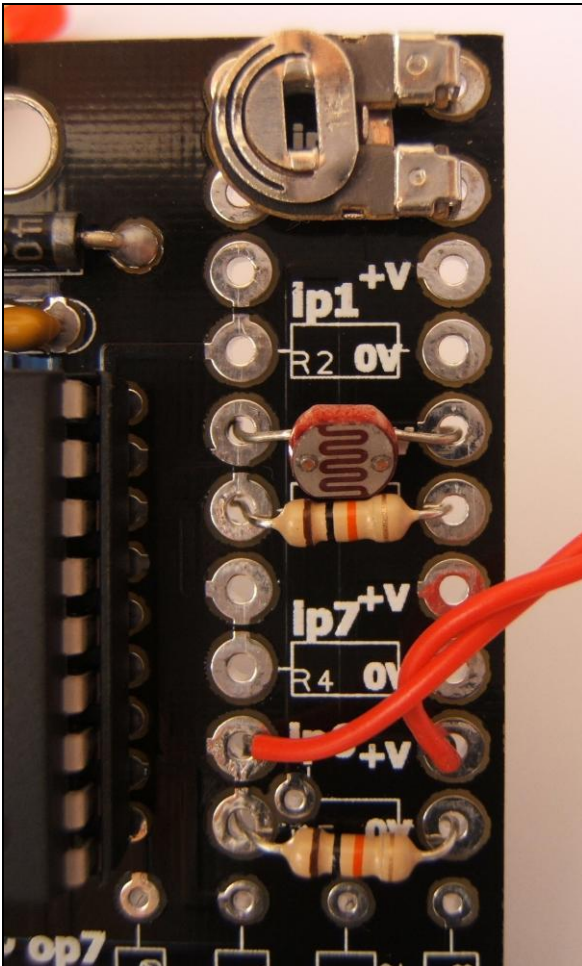

Here the input section can be seen close up. It can be seen from ip1 that the inputs are set up as potential dividers and the +V and 0V are clearly labelled.

For the preset resistor 1k has been used, it is not recommended to use a high value as it will affect the a2d conversion. The analogue value from the preset can be read using the appropriate function in your software. Ip2 has been used.

The LDR and resistor can be used to detect when it is light or dark. This can be done with an a2d conversion but as the LDR has a very wide resistance range it can also be read like a digital switch. Ip0 has been used.

The PTM switch and 10k pull down resistor would be read as a digital signal, either on or off. The state of the switch would be read in software as high or 1 for pressed and low or 0 for not pressed. It is important to use a pull up or pull down resistor and if the switch and resistor were reversed then a press would give a 0 or low signal.

Please visit our website

www.rkeducation.co.uk

If you have any comments or queries please email us at

technical@rkeducation.co.uk

