

RKP18Relay8 Component List and Instructions

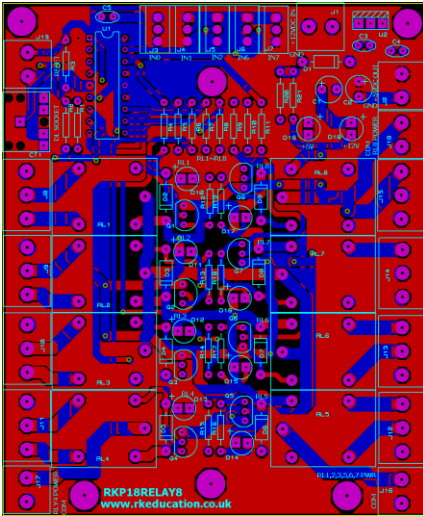

PCB layout

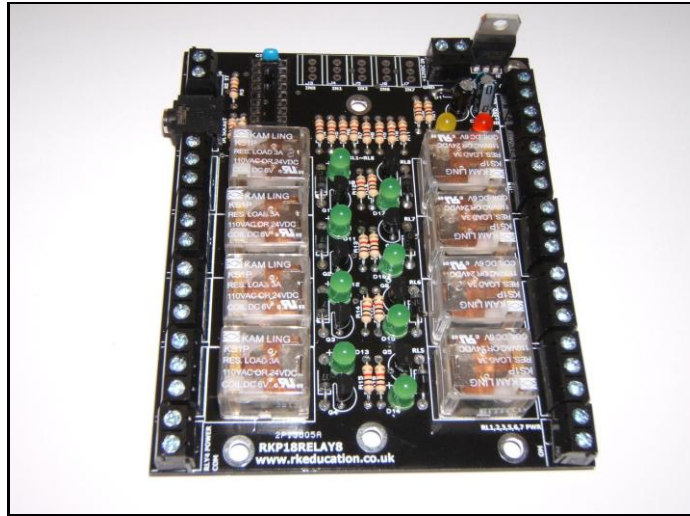

Constructed PCB

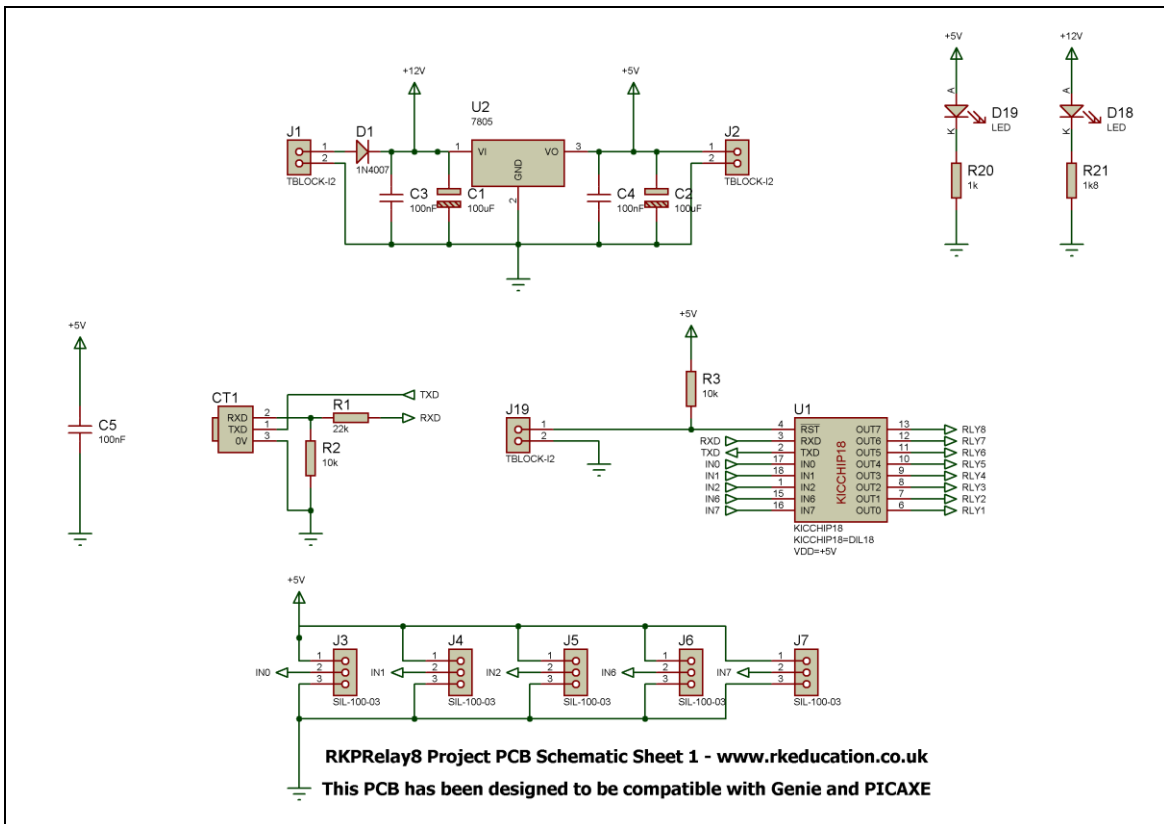

Schematic Sheet 1

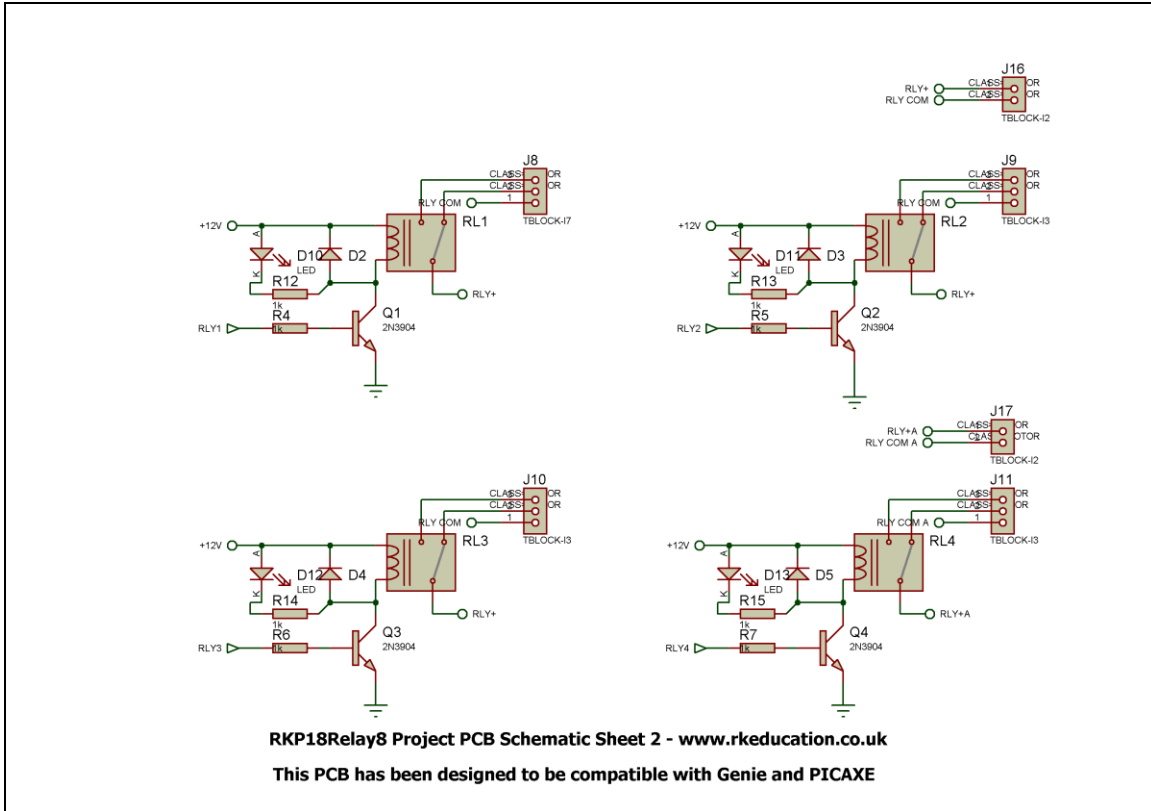

Schematic Sheet 2

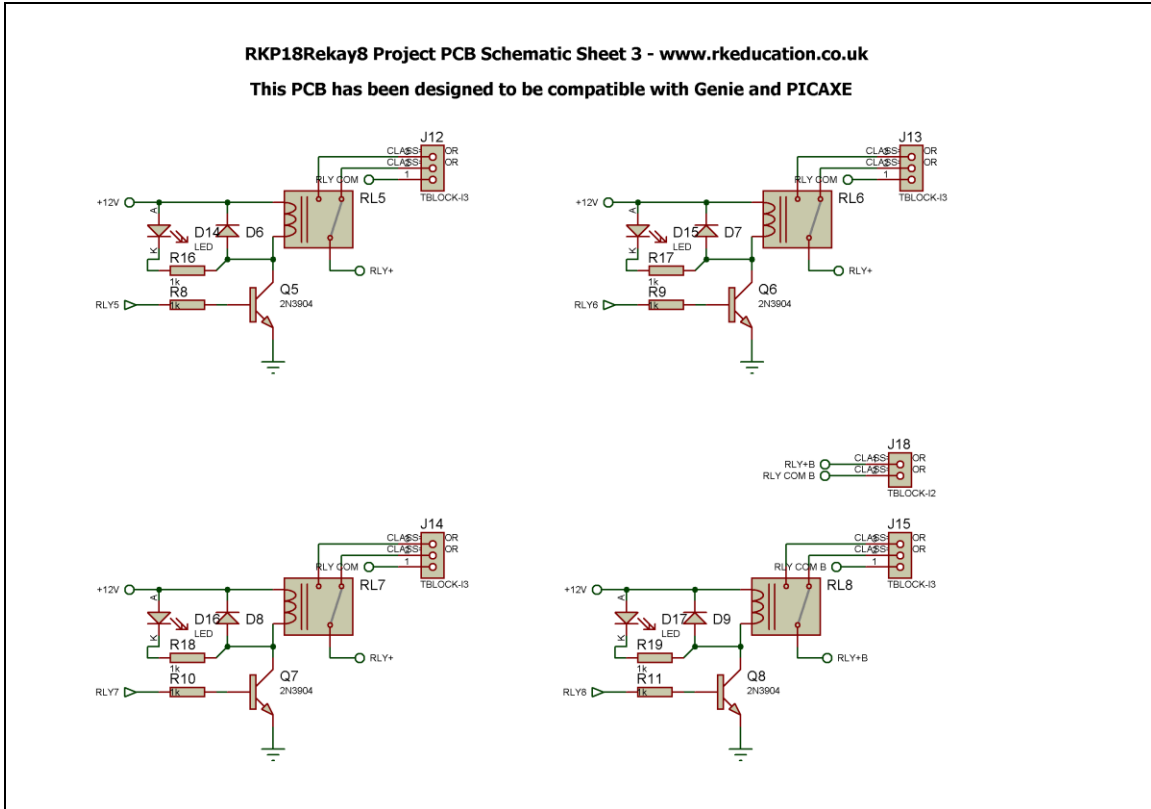

Schematic Sheet 3

Description

The RKP18Relay8 project PCB has been designed to use PIC microcontrollers such as the Genie or PICAXE

- Software is downloaded from a PC into the microcontroller via a 3.5mm stereo socket
- The clock reference is from a the microcontrollers internal resonator
- 8 outputs are connected to Kam Ling SPDT relays
- Power to the relay contacts is from several external sources
- Each relay has an LED to show when it is energised
- 5 potential divider inputs, 3 can be used as analogue
- Power is via a 2 way terminal block
- +12VDC input and +5VDC regulated output
- 2 LEDs used to indicate power, +12V and +5V
- The PCB has 6 mounting holes for sturdiness
- Thick tracks are used and extra thick where needed

Component List

J1, J2, J16 ~ J19 – 2 way 5mm pitch terminal block

J8 ~ J15 – 3 way 5mm pitch terminal block

J3 ~ J7 – 3 way SIL socket

C1, C2 – 100uF electrolytic capacitor 25VDC

C3 ~ C5 – 100nF multilayer ceramic capacitor

CT1 – PCB mount 3.5mm stereo connector

D1 ~ D9 – 1N4007

D10 ~ D17 – 5mm LEDs green, yellow and orange (indicators)

Q1 ~ Q7 – NPN TO92 transistors MPSA13

R1 – 22k ¼ watt resistor (red red orange)

R2, R3 – 10k ¼ watt resistor (brown black orange)

R4 ~ R20 – 1k ¼ watt resistor (brown black red)

R21 – 1k8 ¼ watt resistor (brown grey red)

RL1 ~ RL8 – SPCO miniature PCB power relays

U1 – 18 way DIP socket with microcontroller e.g. Genie

U2 – 7805 voltage regulator TO220 package

When constructing always start with the components that have the lowest profile and work high, for example start with the resistors and end on the 7805 voltage regulator.

Instructions

For instructions on using your chosen microcontroller, e.g. kicchip please see the appropriate website.

Please only attempt to use this product if you are qualified to do so, if in doubt please seek professional advice.

Connecting Power

The power is connected to the terminal block marked +12VDC IN, the 0V input, usually black is put in the left hand side terminal and the +VE, usually red, is put in the right hand side terminal, a regulated 12VDC 1Amp power supply or 12VDC battery should be used. The circuit incorporates a 7805 voltage regulator and 5VDC is available at the terminal block +5VDC OUT, a heat sink will need to be added to the 7805 if a high current is required to prevent damage to the circuit.

Downloading software

Once the software has been written using the Genie Programming Editor (or equivalent) it can be downloaded into the Genie (or equivalent). This is downloaded using a download cable that connects either to your PC's serial port or USB port. Insert the download plug into the download socket and activate the program function in your Programming Editor. If all goes well it will tell you the program download was successful.

Using the relays

Power to the relay contacts is from a separate supply to the main power supply, this allows the use of AC voltages if needed, do not use AC unless you are qualified to do so. If you want to use the main power supply then connect the power supply to the appropriate relay power terminal block, these are labelled,

RL1,2,3,5,6,7 PWR
RL4 POWER
RL8 POWER

This arrangement allows different voltages to be used with the relays, RL1,2,3,5,6,7 all have the same supply and RL4 and RL8 have

separate supplies, if all relays are to use the same supply then the terminal blocks will need to be connected together.

The relays are energised by powering the transistors Q1 ~ Q8, this is done by turning on the output pins outputs 1 ~8 on the microcontroller. When a relay is energised a click can be heard and when it returns to its non energised state a further click can be heard, the movement can be seen in the top of the relay. The green LEDs near the relays provide a visual indication of when the relay is energised.

The relays are connected to the microcontroller in the following way,

PIN 6	OP0	RL1
PIN 7	OP1	RL2
PIN 8	OP2	RL3
PIN 9	OP3	RL4
PIN 10	OP4	RL5
PIN 11	OP5	RL6
PIN 12	OP6	RL7
PIN 13	OP7	RL8

Sending logic 1 or high to the transistor will turn on the relay.

Each relay has 3 connections that are located on the 3 way terminal block, they are called COM – common – pin 1, NC – normally connected – pin 2 and NO – normally open – pin 3. When the relay is not energised there is a circuit between COM and NC and when the relay is energised there is a circuit between COM and NO. To power a DC motor connect one lead to COM and one to NC, the motor will be powered until the relay is energised and the circuit changes to between COM and NO, if the motor leads were between COM and NO then this would be reversed.

Inputs Ip0 ~ Ip7

These are used as digital inputs and Ip0, Ip1 and Ip2 can also be used as analogue inputs. They are arranged as potential dividers with the +5VDC the lower pin and 0V the upper pin, the centre of the potential divider or output is the central pin. These inputs have been designed to accept a 3296 type potentiometer. No pull up or pull down resistors have been included and they will have to be added if needed.

They are connected to the microcontroller as follows,

ip0 – pin17
ip1 – pin18
ip2 – pin1
ip6 – pin15
ip7 – pin16

Please visit our website

www.rkeducation.co.uk

If you have any comments or queries please email us at

technical@rkeducation.co.uk