

RKP14lp Component List and Instructions

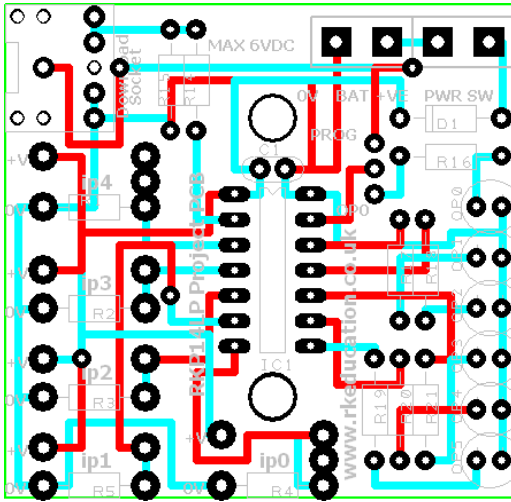

PCB layout

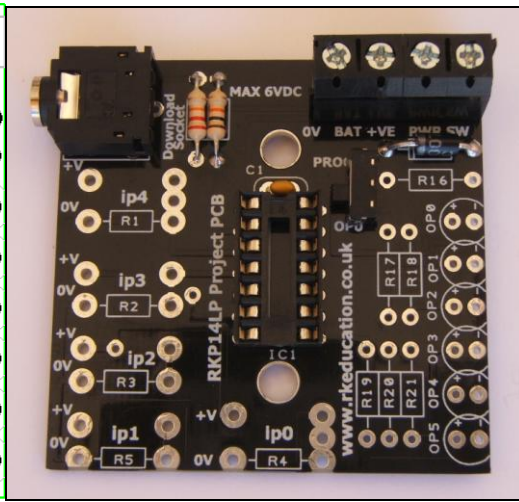

Constructed PCB

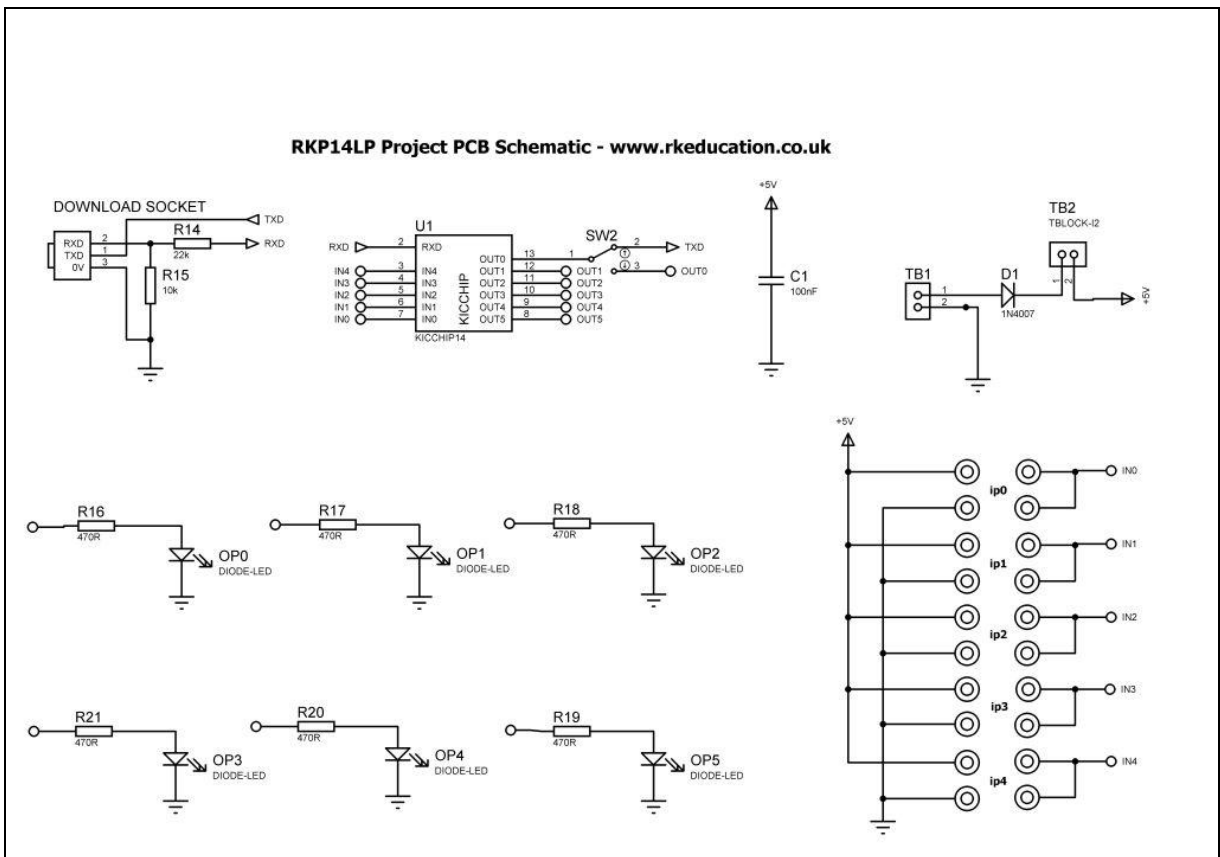

Schematic

Description

The RKP14lp project PCB has been designed to use PIC microcontrollers such as PICAXE and Genie

- Software is downloaded from a PC into the microcontroller via a 3.5mm stereo socket
- The clock reference is from a the microcontrollers internal resonator
- 6 low power outputs – ideal for LED projects e.g. dice
- 5 potential divider inputs
- ip0 and ip4 can have a PCB mount potentiometer directly mounted
- A slide switch is used to change pin 13 between OP0 and program chip

Component List

BAT and PWR SW - 2 way 5mm pitch terminal blocks for power supply and power switch

1 ultra miniature slide switch for program switch

C1 – 100nF multilayer ceramic capacitor

D1 ~ D5 – 1N4007

IC1 – 14 way DIP socket with microcontroller e.g. Genie

R14 – 22k red red orange

R15 – 10k brown black orange

Software download socket – PCB mount 3.5mm stereo connector

Instructions

For instructions on using your chosen microcontroller, e.g. Genie, please see the appropriate website.

Connecting Power

The power is connecting the terminal block marked Battery, the 0V input, usually black is put in the left hand terminal and the +VE, usually red, is put in the right hand terminal, a regulated 6VDC power supply should be used. A power switch can be added to the terminal block marked PWR SW, if a switch is not needed short the terminal block's terminals.

Downloading software

Once the software has been written using the Genie Programming Editor (or equivalent) it can be downloaded into the Genie (or equivalent). This is downloaded using a download cable that connects either to your PC's serial port or USB port. Insert the download plug into the download socket and activate the program function in your Programming Editor, the slide switch labelled pin7 must be set to **PROG**, it will need to be set to **OPO** when the software is being executed. If all goes well it will tell you the program download was successful.

Using the inputs and outputs

Pin13 can be set as program or op0 using a slide switch.

Low Power Outputs

These outputs have been designed with LEDs in mind making this project PCB excellent for dice projects. To turn an output on simply turn on the corresponding output on in your software. The outputs are op0 to op5 and are connected to pins 13 to 8 on the microcontroller. A suitable value for the resistor may be 470R, LEDs will likely be attached using flying leads.

Inputs Ip0 ~ Ip4

These are used as digital inputs and can also be used as analogue inputs should your chosen microcontroller allow this. They are arranged as potential dividers with the +V and 0V parts clearly marked, the centre of the potential divider or output are the 2 pads to the right hand side of the potential divider. Ip0 and Ip4 have been designed to allow a PCB mounting potentiometer to be soldered directly to the PCB.

Please see below for an example of using inputs

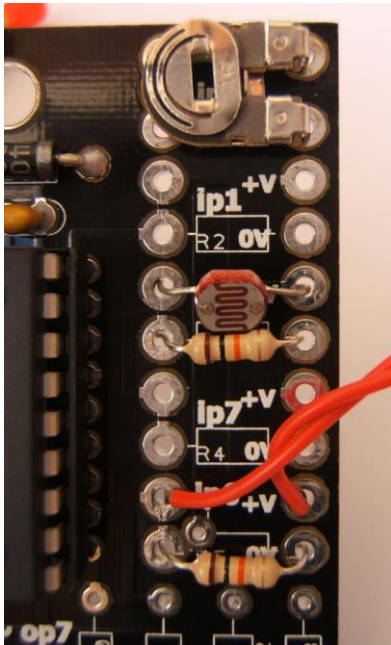

Here the input section can be seen close up. It can be seen from ip1 that the inputs are set up as potential dividers and the +V and 0V are clearly labelled.

For the preset resistor 1k has been used, it is not recommended to use a high value as it will affect the a2d conversion. The analogue value from the preset can be read using the appropriate function in your software. Ip2 has been used.

The LDR and resistor can be used to detect when it is light or dark. This can be done with an a2d conversion but as the LDR has a very wide resistance range it can also be read like a digital switch. Ip0 has been used.

The PTM switch and 10k pull down resistor would be read as a digital signal, either on or off. The state of the switch would be read in software as high or 1 for pressed and low or 0 for not pressed. It is important to use a pull up or pull down resistor and if the switch and resistor were reversed then a press would give a 0 or low signal.

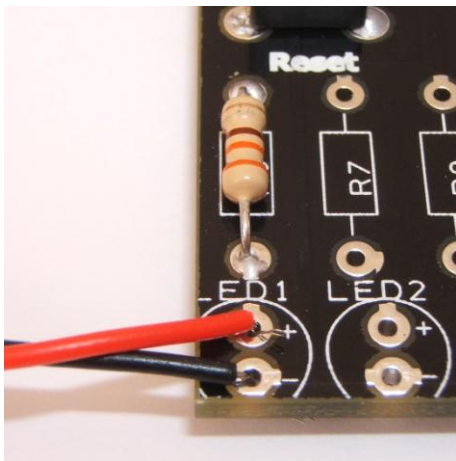

Here is an example of using an LED, to turn on this LED a high signal or logic 1 would be sent to op0, if op1 were being used then the signal would be sent to op1.

When inserting LEDs be careful with polarity, remember the long leg.

In this example a 330R resistor has been used but other values can be used. It is recommended not to use less than 270R.

Please visit our website

www.rkeducation.co.uk

If you have any comments or queries please email us at

technical@rkeducation.co.uk

