

RKP14C Component List and Instructions

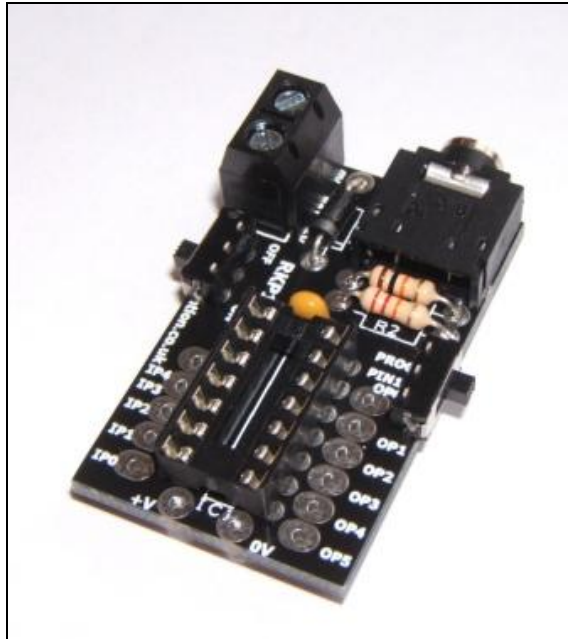

Constructed PCB

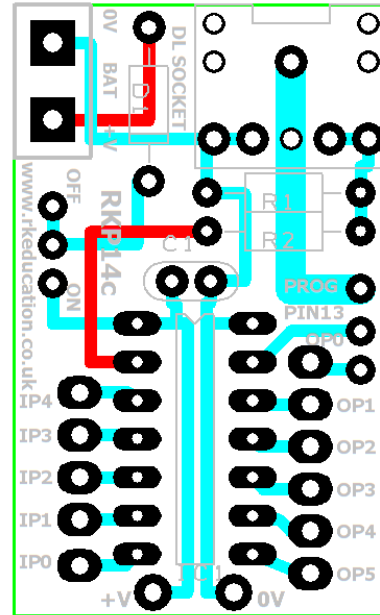

PCB Layout

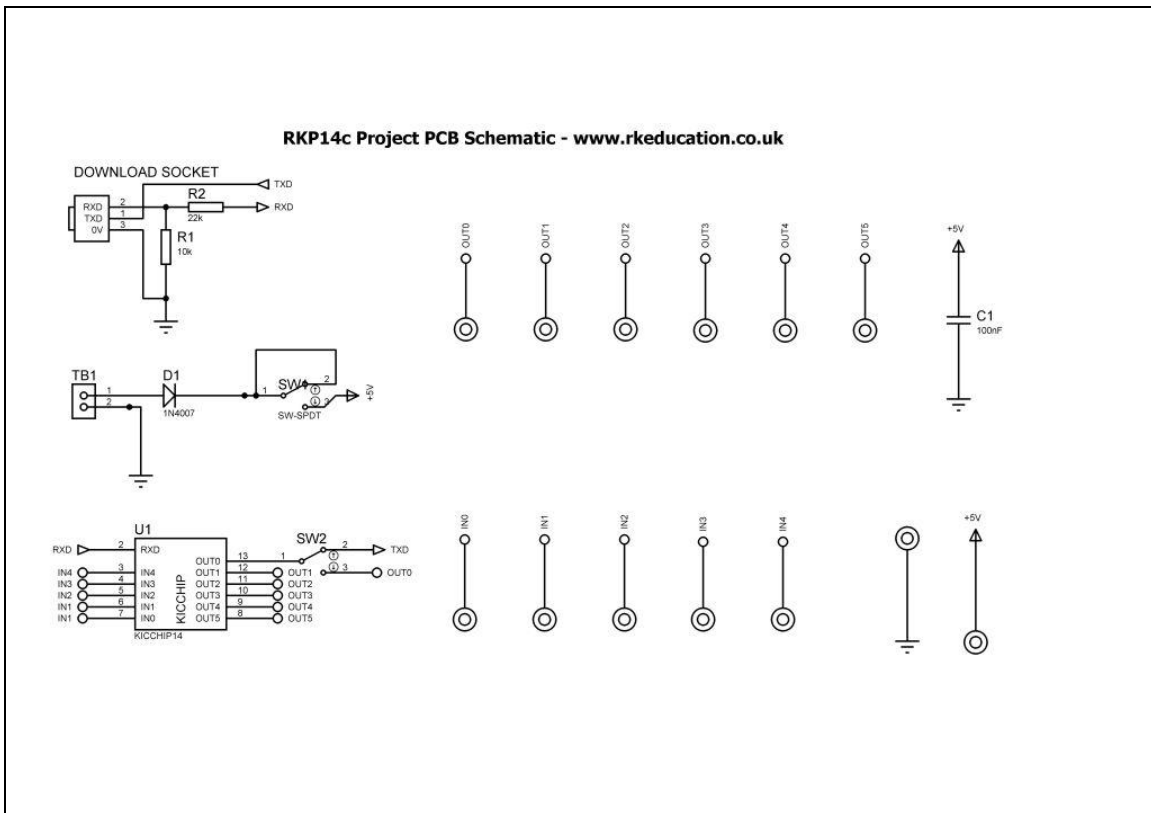

Schematic Diagram

Description

The RKP14C compact project PCB has been designed to use PIC microcontrollers such as Genie and PICAXE

- Software is downloaded from a PC into the microcontroller via a 3.5mm stereo socket
- All input and output pins have a PTH
- Easily interfaced to peripheral devices
- Power supplied via a terminal block - 6VDC is recommended
- Power switch and LED power indicator

Component List

C1 - 100nF multilayer ceramic capacitor

D1 - 1N4007

IC1 - 14 way DIP socket with microcontroller e.g. Genie

R1 - 10k $\frac{1}{4}$ watt resistor (brown black orange)

R2 - 22k $\frac{1}{4}$ watt resistor (red red orange)

DL SOCKET - PCB mount 3.5mm stereo connector

TB1 - 2 way 5mm pitch terminal block for power supply

Ultra miniature slide switches for power switch and program select switch

Instructions

The PCB has been designed to use microcontrollers based on PIC, e.g. Genie, for instructions on using your chosen microcontroller please see the appropriate website.

Connecting Power

The power is connecting the terminal block TB1, the 0V input, usually black is marked clearly as is +V which is usually red, a regulated 6VDC power supply can be used, other voltages may be used as required. The recommended maximum voltage for the PIC is 5.5VDC, the 6VDC supply is reduced by approximately 0.7VDC by diode D1, D1 may be left out but if this is done adjust the supply voltage accordingly.

A power switch has been included and is below TB1.

Downloading software

Once the software has been written using the Genie Programming Editor (or equivalent) it can be downloaded into the Genie (or equivalent). This is downloaded using a download cable that connects either to your PC's serial

port or USB port. Insert the download plug into the download socket and activate the program function in your Programming Editor, the slide switch labelled pin7 must be set to **PROG**, it will need to be set to **OPO** when the software is being executed. If all goes well it will tell you the program download was successful.

Using the I/O pins

Using the i/o pins is simple and is just a case of soldering jumper wires between the appropriate pin and peripheral. Remember to use a common 0V. Power supply pins have been included below IC1, there is +VE on the left and 0V on the right.

Please visit our website

www.rkeducation.co.uk

If you have any comments or queries please email us at

technical@rkeducation.co.uk

