

RKP08 Component List and Instructions

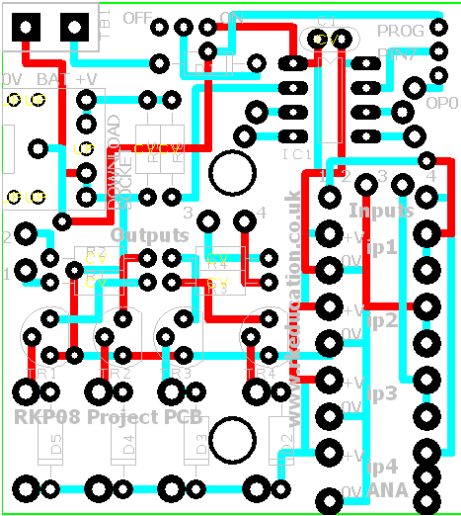

PCB layout

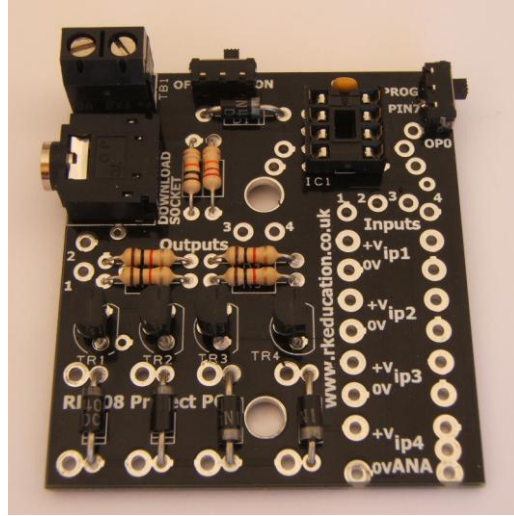

Constructed PCB

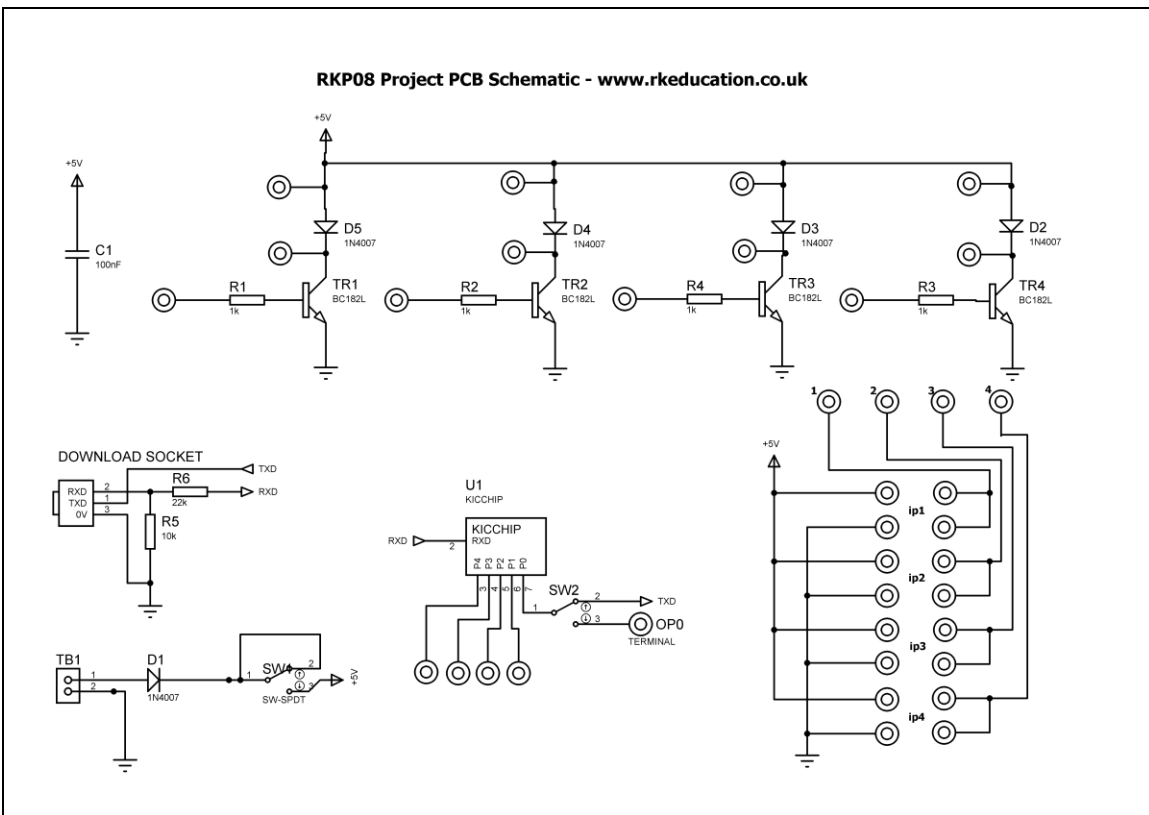

RKP08 Schematic

Description

The RKP08 project PCB has been designed to use PIC microcontrollers such as the Genie or PICAXE

- Software is downloaded from a PC into the microcontroller via a 3.5mm stereo socket
- The clock reference is from a the microcontrollers internal resonator
- Fully utilise all inputs and outputs using jumper wires
- 4 outputs are connected to BC182L transistors
- Transistor outputs have back EMF diodes
- 4 potential divider inputs
- Ip4 can have a PCB mount potentiometer directly mounted
- A slide switch is used to change pin 7 between OP0 and program chip

Component List

TB1 - 2 way 5mm pitch terminal blocks for power supply

2 ultra miniature slide switches for power switch and program switch

C1 - 100nF multilayer ceramic capacitor

D1 - 1N4007

IC1 - 8 way DIP socket with microcontroller e.g. Genie

R1 ~ R4 - 1k brown black red

R5 - 10k red red orange

R6 - 22k brown black orange

Software download socket - PCB mount 3.5mm stereo connector

TR1 ~ TR4 - BC182 transistors

Instructions

For instructions on using your chosen microcontroller please see the appropriate website.

Connecting Power

The power is connecting the terminal block marked Battery, the 0V input, usually black is put in the left hand terminal and the +VE, usually red, is put in the right hand terminal, a regulated 6VDC power supply should be used. The maximum recommended voltage for a PIC is 5.5VDC, the power supply diode will reduce the supply voltage by approx. 0.7VDC.

Downloading software

Once the software has been written using the Genie Programming Editor (or equivalent) it can be downloaded into the Genie (or equivalent). This is downloaded using a download cable that connects either to your PC's serial port or USB port. Insert the download plug into the download socket and activate the program function in your Programming Editor, the slide switch labelled pin7 must be set to **PROG**, it will need to be set to **OP0** when the software is being executed. If all goes well it will tell you the program download was successful.

Using the inputs and outputs

Pin7 can be set as program or op0 using a slide switch.

The PCB has been designed to fully utilise all inputs and outputs, e.g. 2 inputs may be used and 3 outputs or 1 input and 4 outputs. Using the PCBs i/o is simple and involves soldering a wire link between the appropriate input/output and microcontroller.

Transistor Outputs

The BC182L transistors can be turned on by sending a +VE output from the microcontroller, by sending a logic 1 from the software to the appropriate output pin.

Each of the BC182L outputs has a back EMF protection diode and as such a DC motor can easily be added, simply insert the cables from the motor into the appropriate PCB pads, please note a capacitor will need to be used on the motor terminals.

To use an output simply attach flying leads to the appropriate PCB pads.

Inputs Ip1 ~ Ip4

These are used as digital inputs and can also be used as analogue inputs should your chosen microcontroller allow this. They are arranged as potential dividers with the +V and 0V parts clearly marked, the centre of the potential divider or output are the 2 pads to the right hand side of the potential divider. Ip4 has been designed to allow a PCB mounting potentiometer to be soldered directly to the PCB.

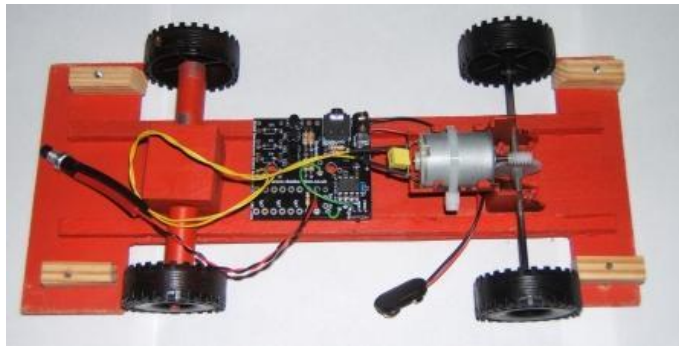

An example of an RKP08 used in a car

Please see below for an example of using inputs

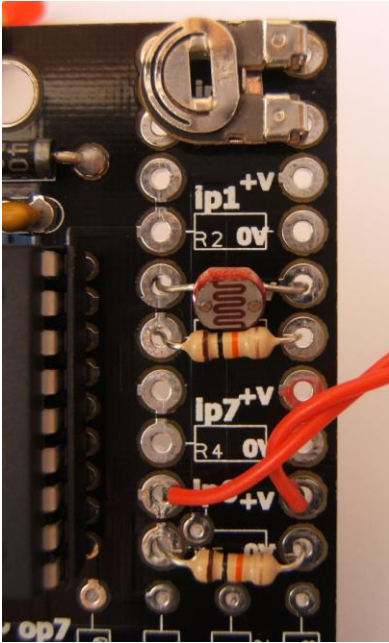

Here the input section can be seen close up. It can be seen from ip1 that the inputs are set up as potential dividers and the +V and 0V are clearly labelled.

For the preset resistor 1k has been used, it is not recommended to use a high value as it will affect the a2d conversion. The analogue value from the preset can be read using the appropriate function in your software. Ip2 has been used.

The LDR and resistor can be used to detect when it is light or dark. This can be done with an a2d conversion but as the LDR has a very wide resistance range it can also be read like a digital switch. Ip0 has been used.

The PTM switch and 10k pull down resistor would be read as a digital signal, either on or off. The state of the switch would be read in software as high or 1 for pressed and low or 0 for not pressed. It is important to use a pull up or pull down resistor and if the switch and resistor were reversed then a press would give a 0 or low signal.

Please visit our website

www.rkeducation.co.uk

If you have any comments or queries please email us at

technical@rkeducation.co.uk

