

## L293D PCB Component List and Instructions

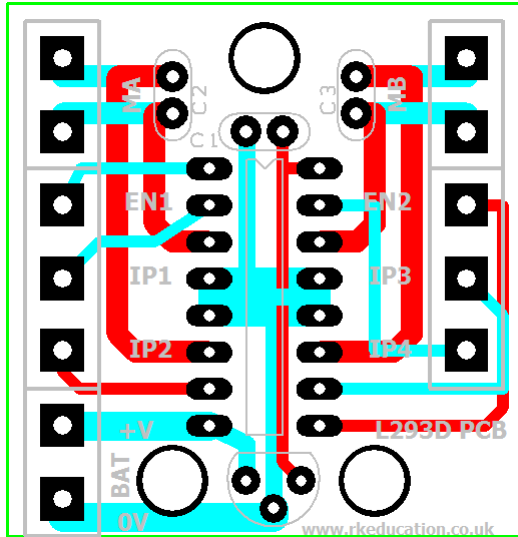

PCB layout

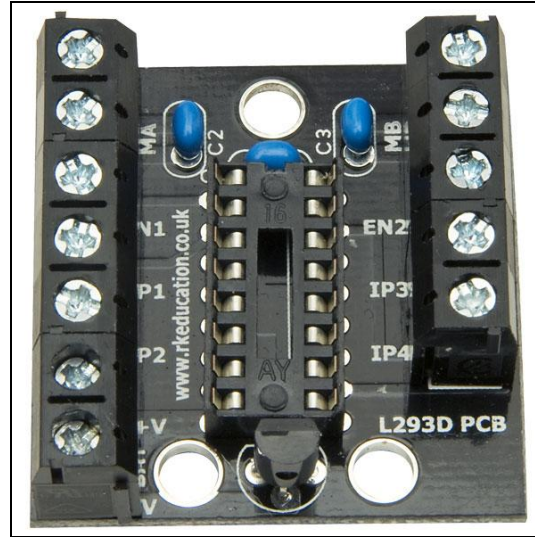

Constructed PCB

### L293D H-Bridge Motor Driver PCB Schematic - www.rkeducation.co.uk

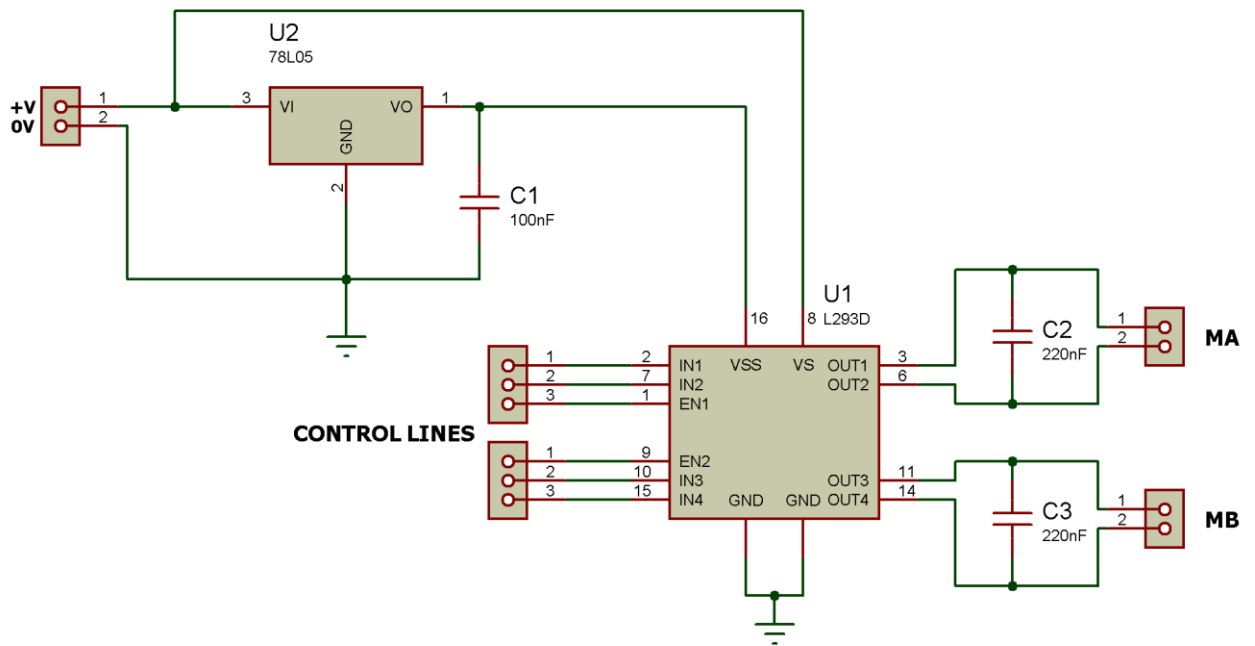

Schematic Diagram

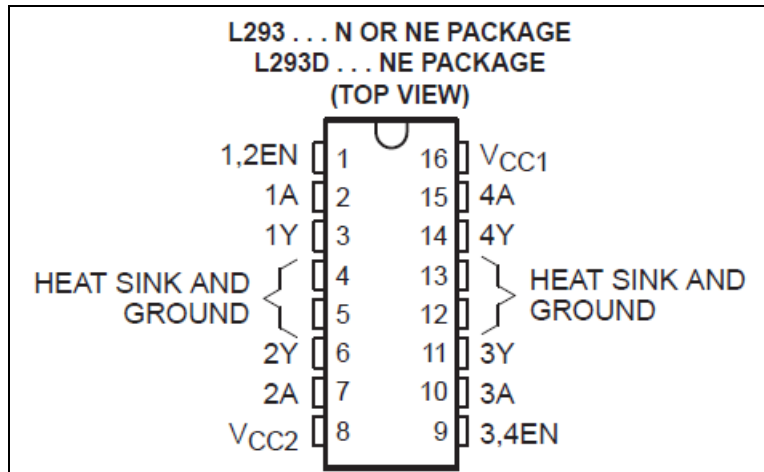

L293D Pinout

## Description

The L293D project PCB has been specifically designed to use the L293D H-Bridge chip and is great for interfacing with PIC and Atmel microcontrollers such as the Arduino, PICAXE and Genie

- A low cost method of producing high power and DC motor projects
- Can be interfaced to various microcontrollers and ICs such as PIC, ATMEL etc
- The control/interface lines are accessible with terminal blocks
- Great for DC motor control projects including vehicles and robots
- Can drive 2 DC motors at 600mA or 1 at 1.2A
- Motors are reversible
- Manufactured using a double sided professional PCB
- Compact design

## Component List

BAT and PWR SW - 2 way 5mm pitch terminal blocks for power supply and power switch

2 x 2 way 5mm terminal blocks

2 x 3 way 5mm terminal blocks

C1 - 100nF multilayer ceramic capacitor

C4, C5 - 220nF multilayer ceramic capacitor

IC1 - 16 way DIP socket with L293D

## Instructions

For detailed information on the L293D dual h-bridge driver please see the appropriate datasheet, this can be found at [www.rapidonline.co.uk](http://www.rapidonline.co.uk)

When constructing PCBs it is advisable to start with the components with the lowest profile, for example resistors, with this PCB start with the IC socket.

## Connecting Power

The power is connected to the terminal block marked Battery, the 0V input, usually black is put in the left hand terminal and the +VE, usually red, is put in the right hand terminal, a regulated DC power supply should be used. A power switch can be added to the terminal block marked POWER SW, if a switch is not needed short the terminal block's terminals.

## Using the L293D

The L293D is an h-bridge drive chip, for more information on this chip please refer to a datasheet for this device, see [www.rapidonline.co.uk](http://www.rapidonline.co.uk)

The L293D powers two motors at up to 600mA each or 1 motor up to 1.2A, motors are reversible, the outputs to the motors are clearly marked **MA** and **MB**. The motors are controlled by sending appropriate output signals from the microcontroller to the L293D, the L293D must be enabled and 2 inputs marked **EN1** and **EN2** are used, to enable send a logic 1 to the appropriate enable input, the chip may be permanently enabled if required. To control motors use the following as a guide,

Microcontroller		L293D	
Pin x	to	pin 7	MA
Pin x	to	pin 2	MA
Pin x	to	pin 15	MB
Pin x	to	pin 10	MB

Both inputs low	- motor stop
First output high, second output low	- motor forward
First output low, second output high	- motor reverse
Both inputs high	- motor stop

To attach a motor simply screw the flying leads from the motor into the appropriate terminal block.

Please note that if you use the L293D near to its maximum limits then a heat sink will need to be used.

Please visit our website

[www.rkeducation.co.uk](http://www.rkeducation.co.uk)

If you have any comments or queries please email us at

[technical@rkeducation.co.uk](mailto:technical@rkeducation.co.uk)

L293D H-Bridge Motor Driver PCB Schematic - www.rkeducation.co.uk

