

### 4 Siren Generator and Flashing Lights Component List and Instructions

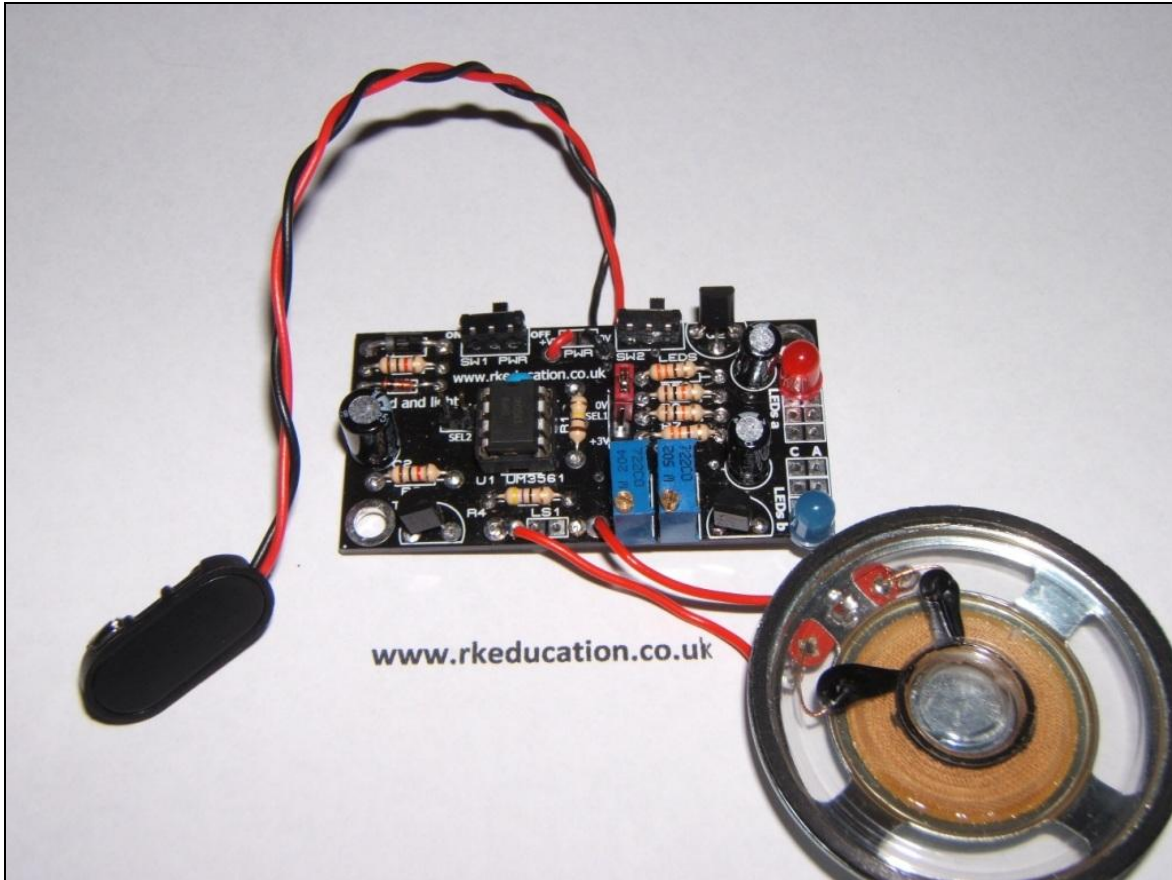

Constructed PCB

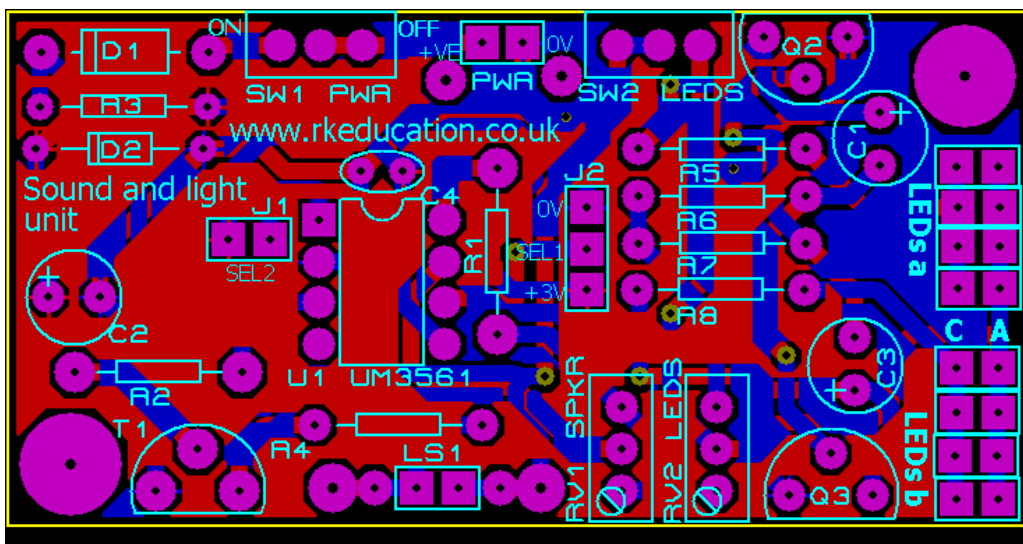

PCB layout

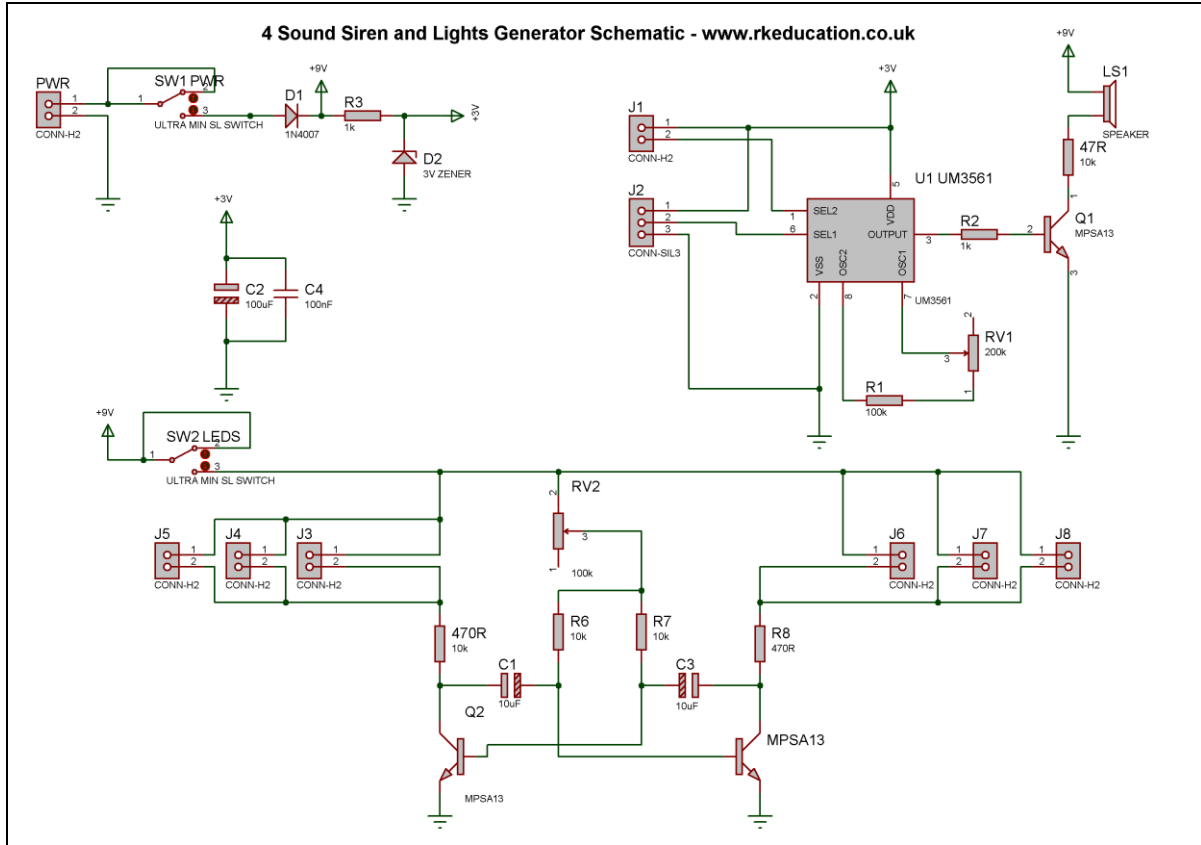

Schematic Diagram

## Description

This project PCB has been specifically designed to use the UM3561 siren generator chip and is great for integrating into models.

- A low cost method of producing emergency vehicles
- Perfect for models
- Has 4 different sirens
- The siren is selected using a PCB jumper
- The pitch of the siren can be varied
- Includes space for 8 LEDs, in 2 groups of 4
- LEDs flash
- Flashing frequency can be varied
- LEDs can be turned on and off independent of the siren
- Battery powered
- Uses a high quality speaker
- Manufactured using a double sided professional, black PCB
- The PCB has mounting holes
- PCB has a clear silkscreen
- Compact design

## Component List

PWR – for battery clip, ensure correct polarity, the holes either side can be used to thread the battery clip leads

J1 - 2 way header (SEL2)

J2 - 3 way header (SEL1)

C1, C3 – 10uF electrolytic capacitor, these control the frequency of LED flashing and can be varied

C2 – 10uF electrolytic capacitor

C4 – 100nF multilayer ceramic capacitor

D1 – 1N400x diode

D2 – 3V3 zener diode

LS1 – speaker, attach using flying leads

R1 – 100k resistor (brown, black, yellow)

R2, R3 – 1k resistor (brown, black, red)

R4 – 47R (yellow, violet, black)

R5, R8 – 470R (yellow, violet, brown)

R6, R7 – 10k (brown, black, orange)

RV1, RV2 – variable resistors

SW1, SW2 – ultra miniature slide switch

Q2, Q3 – MPSA13 transistor

T1 – MPSA13 transistor

U1 – 8 way DIP socket with UM3561

## Instructions

For detailed information on the UM3561 please see the appropriate datasheet, this can be found at [www.rapidonline.co.uk](http://www.rapidonline.co.uk)

When constructing PCBs it is advisable to start with the components with the lowest profile, for example resistors, and end with the components with the highest profile, for example capacitors.

It will be necessary to attach wires or speaker cables to the speaker, the speaker should be connected to the PCB by soldering the speaker wires to LS1 . Extra pads have been included for greater flexibility, normally the 2 pads in the centre should be used.

Wires will also normally need to be added to the LEDs. The PCB has space for up to 8 LEDs, 4 either side of the transistor astable.

## Connecting Power

The power is connected to the PCB pads marked PWR, the 0V input, usually black is put in the right hand terminal and the +VE, usually red, is put in the left hand terminal, a 9V battery should be used. A power switch is included and is labelled SW1, alternative switches can be used, if a switch is not needed a short will need to be used.

### **Using the PCB**

When powered and if the PCB has been constructed correctly the siren will sound, by changing the position of the header socket the sound of the siren will change, there are 4 different sirens.

The PCB also includes a section for flashing up to 8 LEDs, this section of the PCB is based around a transistor astable circuit. The frequency can be varied using RV2.

The pitch of the siren can be varied by adjusting the variable resistor RV1.

Please visit our website

[www.rkeducation.co.uk](http://www.rkeducation.co.uk)

If you have any comments or queries please email us at

[technical@rkeducation.co.uk](mailto:technical@rkeducation.co.uk)

